



# Comet Series

## Comet-S1000 & S1200

Experience a new level of safety with this compact design speed gate

### Introduction

The Comet Series is an innovative multi-credential speed gate featuring a sleek, transparent design that fits seamlessly into corporate settings. Available in single-lane and Multiple lanes, these gates combine advanced functionality with a lightweight yet robust chassis made of distinctive cast aluminum alloy. They offer customizable ambient lighting with 7 RGB colours to enhance the user experience. The Comet Series revolutionizes facial verification with eight undercount options and an ultra-wide-angle lens, ensuring optimal performance for individuals of varying heights. The series supports biometric, RFID, palm, face and blue tooth verification and QR code options, and offers flexible lane combinations and diverse color choices to meet specific requirements. Security is enhanced with locked positions, clutch engagement, and automatic barrier opening in emergencies.

#### Multiple Undermount Options

The Comet Series barriers offer a variety of undermount plates to cater to different credential needs. These include:

- RFID
- QR Code
- Fingerprint
- Facial Verification
- Palm Recognition



#### Integrated Facial Recognition model

##### Wide-Angle Undermount Facial

Recognition Camera Design

Covering a height range from 59" to 74" (1500mm to 1900mm) and offers a recognition distance as far as 68" (1750mm).



#### Basic model

No Facial Verification Camera

#### Customizable Ambient Lighting

The Comet Series features customizable ambient lighting, providing a range of 7 RGB colors. This not only enhances the aesthetic appeal of the speed gates but also serves as an indicator, improving usability and enhancing the user experience.



#### Two Chassis Color Options

The Comet Series provides two color options for its chassis Silver (SLK), & Gold

## Key Features

### Aesthetic Appeal

The Comet Series, the newest addition to our speed gate line, features an elegantly slim and transparent design that seamlessly integrates into various indoor environments.

### Innovative Cast Aluminium

We harness cutting-edge technology to forge a distinctive aluminium alloy for the barrier chassis. This fusion results in a product that combines the lightweight properties of aluminium with the robustness of an alloy.

### Installation-Friendly Design

The Comet Series is designed for ease of installation, featuring newly developed installation mounting plates that can be pre-installed. The barrier is simply placed on the fixed mounting plates to complete the installation, significantly reducing installation time

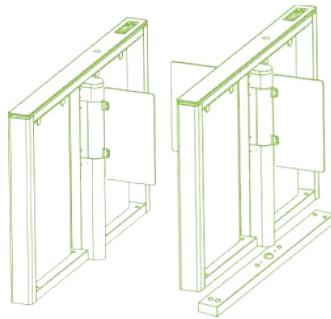

### Ambient LED Visual Indicator

An embedded LED strip is situated along the barrier's side, offering a spectrum of 7 RGB colours and a range of visual effects. This feature is fully customizable to meet our customer's unique preferences.

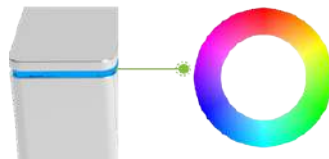

### Multi-Credential Compatibility

The Comet series barrier comes with eight different under-mount lid designs and two top-mount accessory sets, offering a variety of credential options including biometric (Face, Fingerprint), RFID and QR codes (steady and dynamic). Customers can select the options that best meet their needs.



## Flexible Lane Combination and Options

To cater to diverse installation environments, the Comet series is available in two models: Comet-S1000 & S1200. These can be combined to create multiple-lane solutions. Additionally, the Comet series offers several options in sizes ranging from 800mm to 1200mm and in different materials like tempered glass and acrylic, offering the flexibility to meet our customers' specific requirements. Customized etching and graphics for the barriers.



## Streamlined Facial Recognition System Integration

To achieve an optimal balance between streamlined design and functionality, we've reimaged our facial recognition system. By repositioning the monitor, PCB, and camera, we've enhanced performance. The camera is strategically placed just above the motor mechanism, offering a superior viewing angle that accommodates individuals of varying heights, including children, the elderly, and people with disabilities.

### Facial Recognition Camera angle and distance (mm)

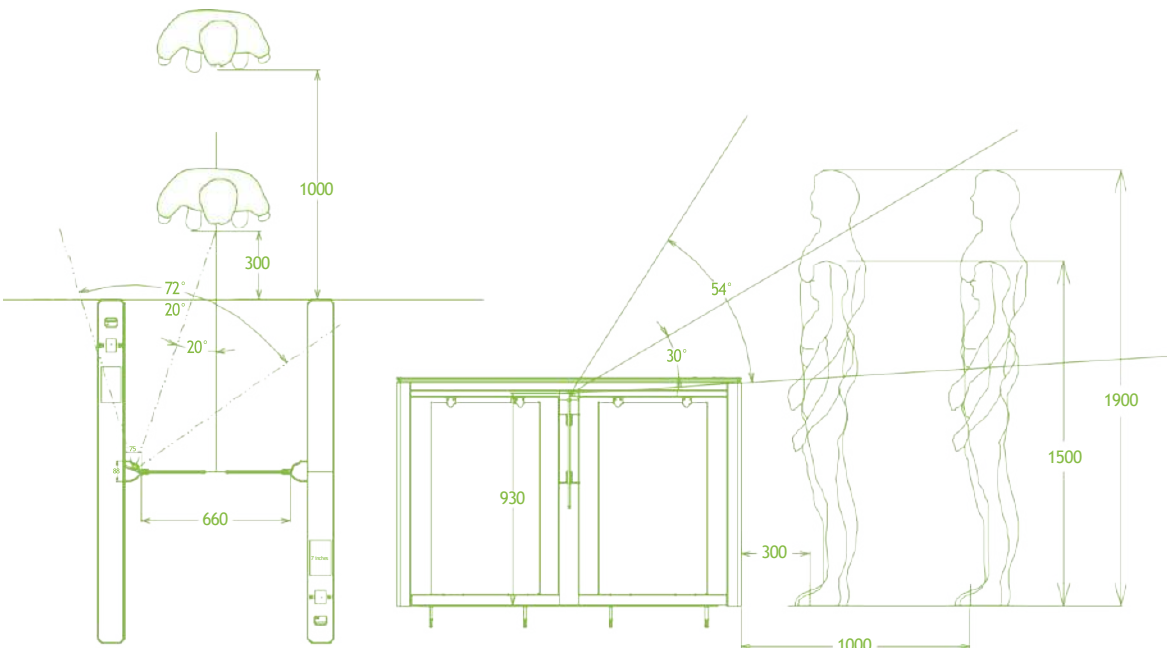

Model	Comet-S1000	Comet-S1200
Audio Indicator	Internal Buzzer	
Visual Indicator	LED strip along the lid (7 Colour RGB, Customizable) Blue: Stand by Steady Green: Normal use Steady Red: Door closing Flashing Red: Alarm	
Display	1 or 2 x 7" IPS touch monitor (Under-mount facial recognition version only)	
Lane Type	Single Lane	Dual wings (with Comet-1200)
Lane Width	660mm (Standard) / 900mm (Optional)	
Barrier Movement Type	Swing	
Motor	DC brushless motor	
Movement Speed	0.5s per movement (open/close timing)	
Movement Accuracy	± 1.5° per movement	
Clutch	Mechanical clutch for anti-panic / anti-collision	
Lid Material	Tempered glass (black) (Standard)	
Lid Options / Authentication Methods	Streamlined under mount options: fingerprint/ RFID / QR Code   fingerprint+ RFID / fingerprint+ QR Code   fingerprint+ RFID + QR Code   facial recognition with display Top mount option: mounting pole (compatible with ProFace X / Speed Face V5L / Elite Pass)	
Chassis Material	Cast aluminium alloy (T=3mm)	
Chassis Colour	Choice of Silver or Gold	
Door Leaf Material (H*W)	Clear acrylic or Clear tempered glass 24.8" x 11.61" (630 x 295mm)	
IR Sensors	8 pairs (Standard) (High position)	
Motherboard Function	Configuration for access mode, anti-pinch, anti-tailgate, etc.	
Motherboard Communication	Fire alarm Port (Relay) x 1, RS485 Port x 1	
Controller	PGIC controller (optional); Others optional based on fit.	
Credential Options	Under mount RFID reader: (support model: ProID Series, Armatura EPI OC & Armatura EP20 Series) under mount QR Code Reader: QR500 under mount fingerprint reader: FR1200 / FR1500 under mount facial recognition terminal: G4 Pro Top mount facial recognition terminal: ProFaceX/ Elite Pass/ Speed Face V5L	
Flow Rate	RFID/QR Code: 30 passengers per minute Fingerprint: 20 passengers per minute Face: 15 passengers per minute	
Accessibility	Under mount facial recognition version: adult, children, disability	
Power Supply	110V / 220V AC @ 50-60Hz	
Power Rating	20VA (Stand by) / 120VA (Operation)	
Fire Signal	Input for voltage-free contact	
Noise Level	Less than 60dB	
MCBF	7 million	

Weight	Gross weight (286.6LB) / Net weight (220LB)	Gross weight (176LB) / Net weight (143LB)
Dimension (LWH)	59" x 4.5" x 39" (1500 x 115 x 1000mm) Standard	
Dimensions With Packing	62.9" x 6.2" x 47" (1600 x 160 x 1200mm) LWH	
Operating Temperature	-18.4°F to 140°F (-28°C to 60°C)	
Operating Humidity	95% RH (non-condensing)	
Certifications	CE, FCC	
Safety Features	<ul style="list-style-type: none"> <li>Safety force sensing</li> <li>* Lower safety sensors</li> <li>* Accurate presence sensing</li> <li>* Emitter/receiver infrared sensors technology</li> <li>* Logic voltage 24V DC</li> <li>* Voltage free contact input for fire alarm fail state</li> <li>* Auto opening on power off</li> <li>* Anti-panic push opening in operation</li> <li>* Wide walkway for wheelchair or easier access</li> <li>* Accompanied wheelchair or child passage management (under mount facial recognition version)</li> </ul>	
Security Features	Anti-intrusion, anti-tailgating, wrong way enter alarm, Automatically close door no one pass	
Product Delivery	Pre-assembled	
Application Environment	Indoor	
Site Preparation	Flat & level finished floor (base plate in options for unfinished floor)	
Security Level	Medium	
Emergency Mode	Support (door unlock automatically)	
Packing Material	Wooden box	

## Color Options



# Dimensions

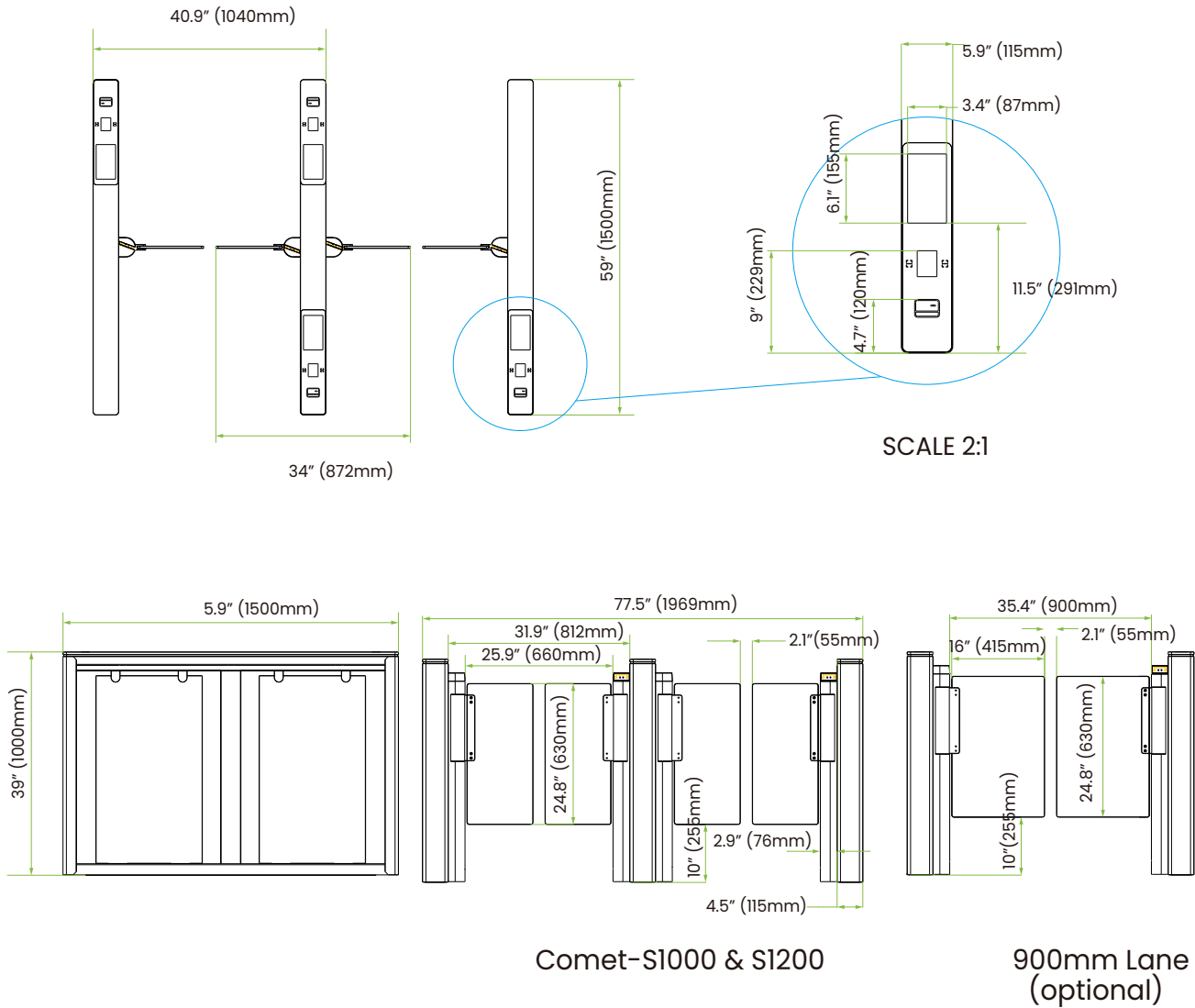

# Application Scenarios



Office Building



Conference



Hotel



Station



1600 Union Hill Road Alpharetta, GA 30005  
 Phone: (862) 505-2101 | Fax: (862) 204-5906 | info@zktcoua.com | www.zktcoua.com

