

Quick Start Guide

AHEC-10 Elevator Control

Bundle

Doc: August 2025

Version: 2.0.0

Table of Contents

- 1. System Overview and Wiring 1**
 - 1.1. System Overview 1
 - 1.2. AHEB-0808/1602 I/O Board — Elevator Panel Wiring Connection 2
 - 1.3. AHEB-1616 I/O Board — Elevator Panel Wiring Connection 3
 - 1.4. Wiring for Multiple I/O Boards 4
 - 1.5. Fire Alarm System Wiring 5
 - 1.6. Emergency Input Wiring 6
 - 1.7. REX Wiring 8
 - 1.8. Alarm Output Wiring 10
- 2. Controller Configuration 11**
 - 2.1. Configuring the Controller for Elevator Control 11
 - 2.2. Configuring the Controller Network Parameters 12
 - 2.3. Configuring the Controller to Software Connection Parameters 13
- 3. Armatura One Software Configuration 14**
 - 3.1. Adding a Device in Spada-MQTT Mode 14
 - 3.2. Verifying Controller Authorization 15
 - 3.3. Adding Buildings, Floors, Elevator Groups, and Elevators 16
 - 3.4. Adding an Elevator Controller 19
 - 3.5. Configuring Reader Parameters 20
 - 3.6. Adding I/O Boards 22
 - 3.7. Modifying Auxiliary Output Points for Floor Assignment 24
 - 3.8. Adding Time Zones and Elevator Levels 25
 - 3.9. Adding Personnel and Configuring Elevator Controls 27
- 4. Verifying Elevator Control Function 28**
- 5. Appendix 1 - Elevator Control and Button Wiring 29**
 - 5.1. Method 1- Common Anode Button Connection 29
 - 5.2. Method 2 - Common Cathode Button Connection 32

1. System Overview and Wiring

1.1. System Overview

1. The Armatura Horizon series controllers and I/O boards are designed to be used not only for access control, but also for elevator control applications. Although a single controller supports both application modes, it can only be configured for either elevator control or access control at one time.
2. The Armatura One software can manage both access control and elevator control simultaneously. By utilizing Armatura One, along with the compatible AH series controllers and I/O boards, a complete one-stop solution can be provided to customers.

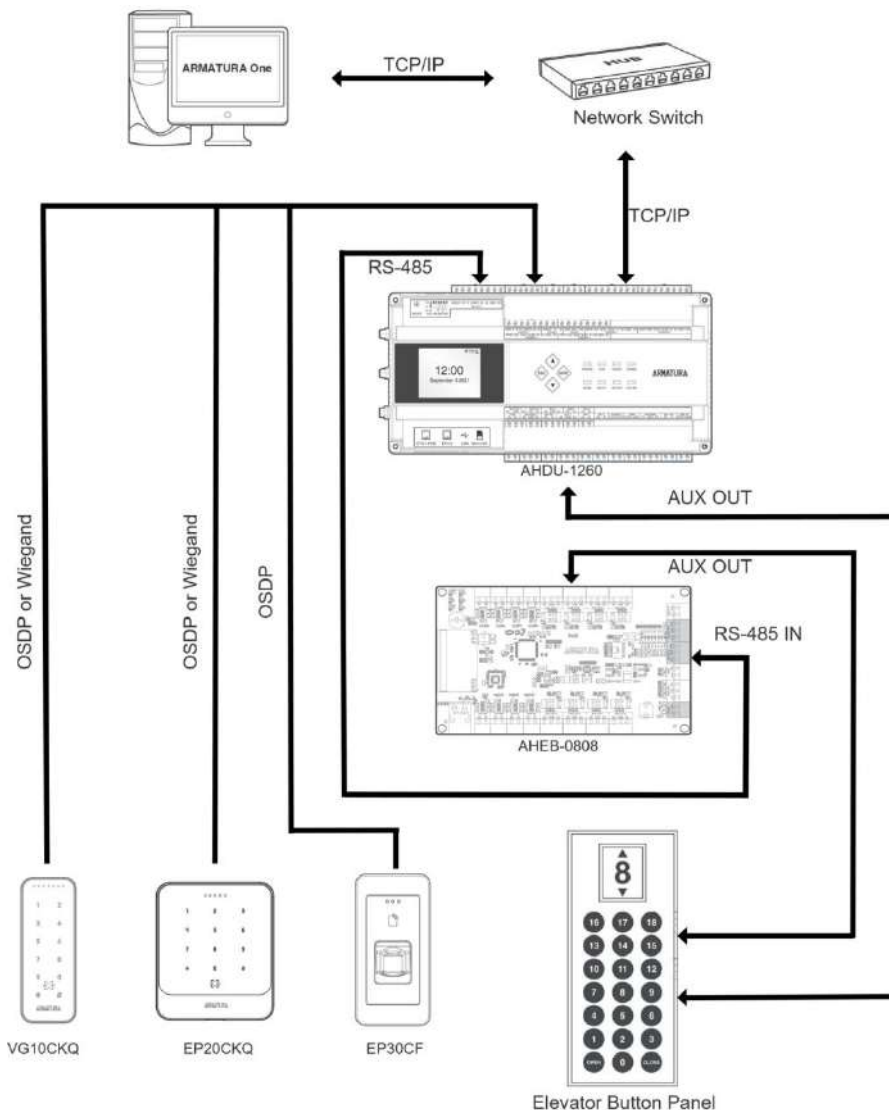

Note:

- 1) One controller can support up to 128 floors.
- 2) The AHEB-0808 and AHEB-1602 boards now support connection to AHSC/AH DU panels for elevator control through a firmware upgrade. Support for the AHEB-1616 will be available soon.

- 3) The AHSC/AHDU controller must be running the MCU firmware version 6.3.2.5 or higher to enable use of the onboard relay for floor control. If the controller is not updated to this version, floor control can only be managed through the auxiliary outputs of the I/O board. For assistance, please contact our technical support team.

1.2. AHEB-0808/1602 I/O Board — Elevator Panel Wiring Connection

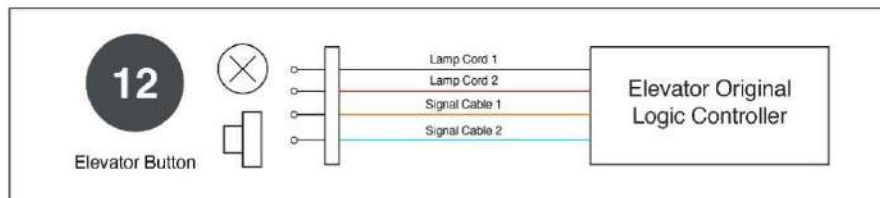
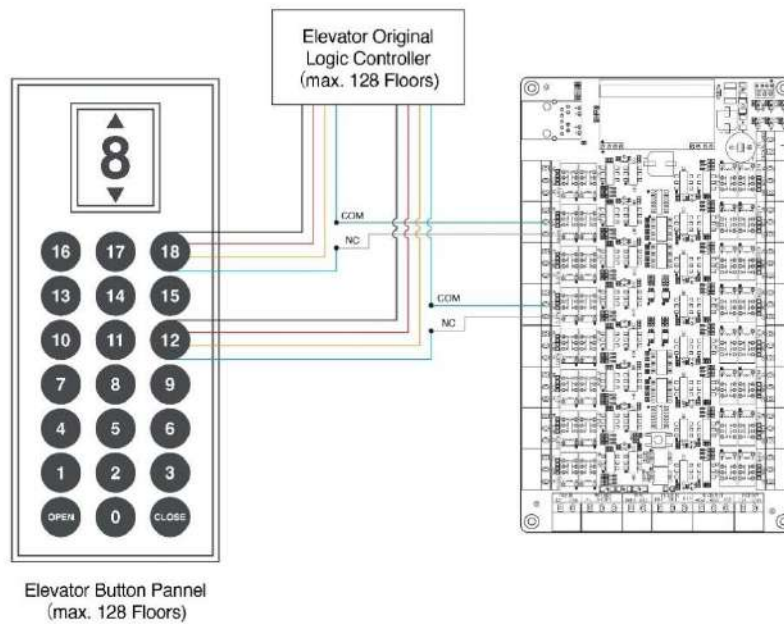

Note:

- 1) The AHEB-0808 and AHEB-1602 do not support **Direct Floor Selection** or **Button Feedback** functions. In this configuration, only the normally closed (NC) terminals and common (COM) terminals of the auxiliary output ports need to be connected in series to the signal lines of the elevator buttons.
- 2) Refer to [Appendix 1 Elevator Control and Elevator Button Wiring](#) for detailed wiring instructions.

1.3.AHEB-1616 I/O Board — Elevator Panel Wiring Connection

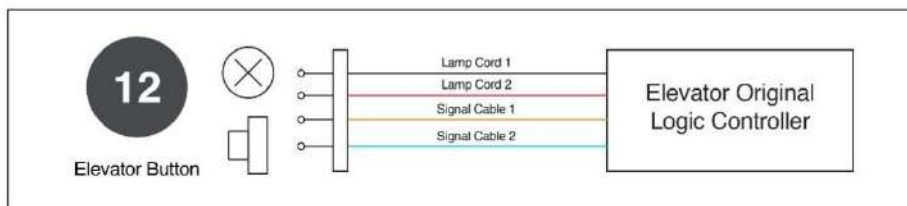
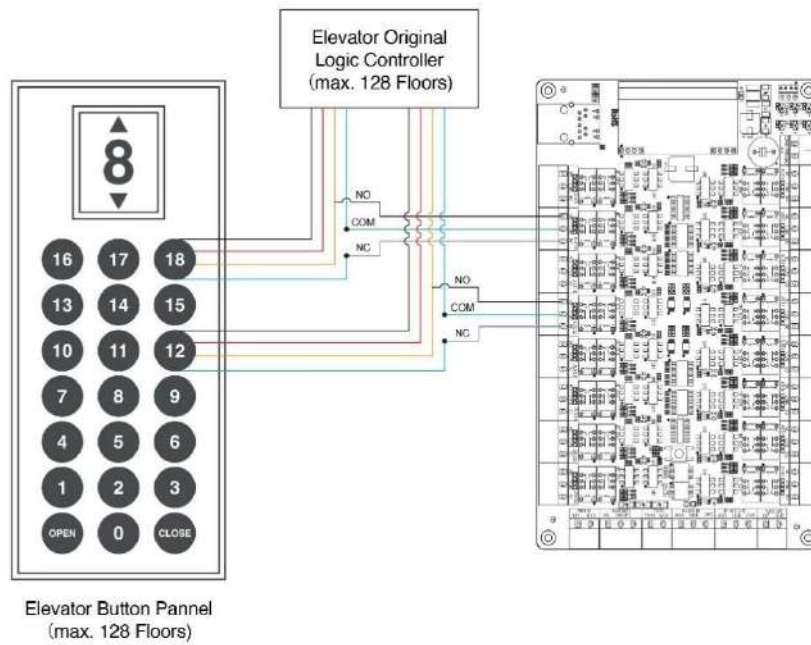

Note :

- 1) The AHEB-1616 supports both **Direct Floor Selection** and **Button Feedback** functions. To ensure proper operation, the normally open (NO), normally closed (NC), and common (COM) terminals of each auxiliary output port must be connected to the signal lines of the elevator floor buttons.
- 2) Refer to [Appendix 1 Elevator Control and Elevator Button Wiring](#) for detailed wiring instructions.

1.4. Wiring for Multiple I/O Boards

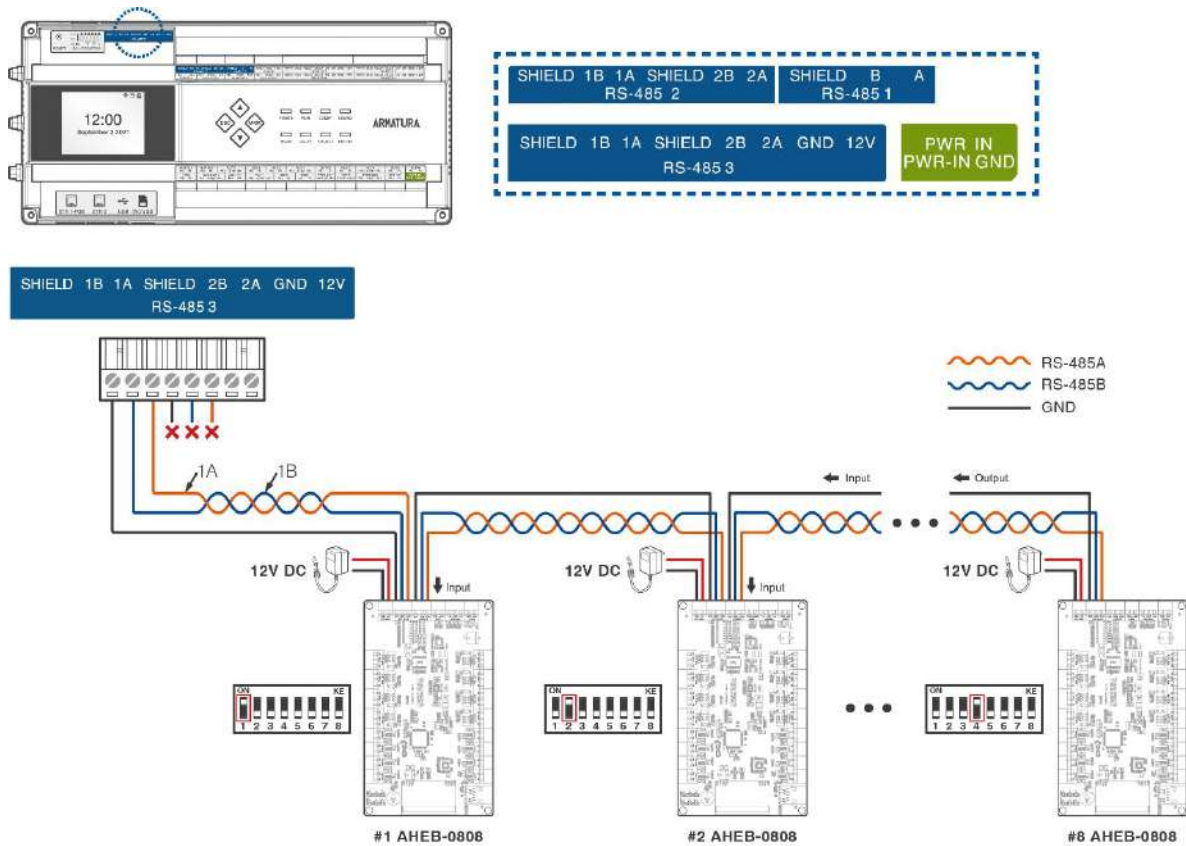

Note:

- 1) Connect the controller's RS-485 interface to the RS-485 IN port of the first I/O board. Then, connect the RS-485 OUT port of the first I/O board to the RS-485 IN port of the next I/O board, and continue this sequence for any additional boards.
- 2) Set the DIP switches on each I/O board to assign a unique RS-485 address, ensuring that no two boards share the same address.
- 3) Provide each I/O board with a dedicated 12V 3A DC power supply to ensure stable operation. A single 12V 3A DC power source can support up to eight I/O boards.

1.5. Fire Alarm System Wiring

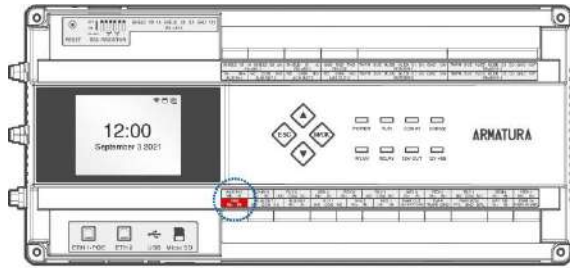

No Supervision

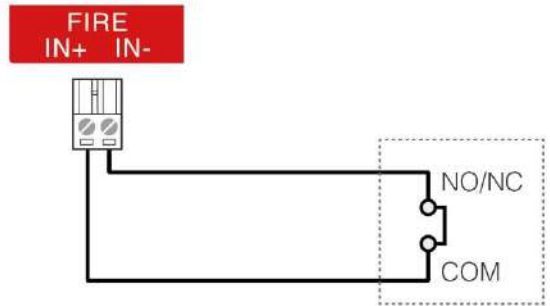

Fire Alarm Panel

Default Supervision

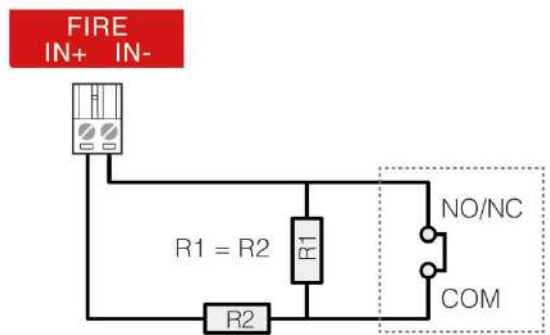

Fire Alarm Panel

Note :

- 1) When a fire alarm is triggered, all elevator buttons are disabled. The fire alarm condition can only be cleared by restarting the device or performing a power cycle.
- 2) The fire alarm connection is an optional feature and does not need to be connected. Connect it only if required for your specific application.
- 3) To enable this feature, the controller must be running MCU firmware **version 6.3.2.5** or higher.
- 4) In this elevator control system, the fire alarm interface has the highest priority, followed by the emergency interface, while the manual interface has the lowest priority in the hierarchy.

1.6. Emergency Input Wiring

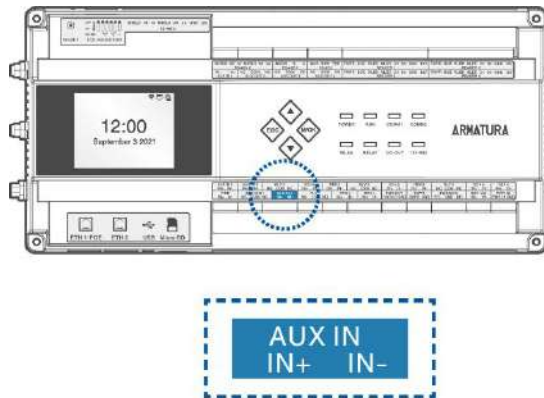

No Supervision

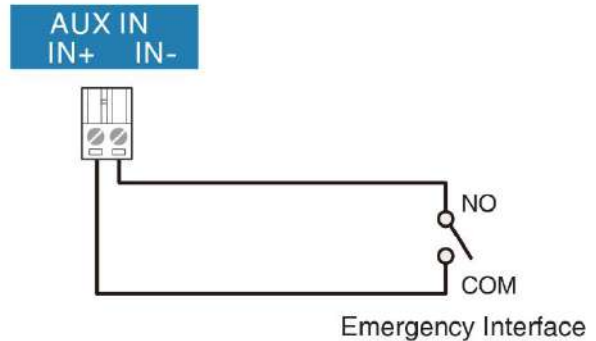

Default Supervision

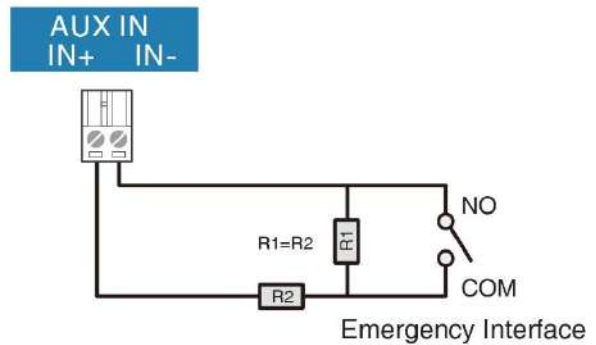

Note :

- 1) In an emergency, when the emergency interface receives a short-circuit signal, the elevator control system will stop managing the elevator buttons, allowing all floor buttons to operate freely. The system can only be restored by restarting the device (power cycle) or by adjusting the settings through the software.
- 2) The Emergency Interface is an optional feature and does not need to be connected. Connect it only if required for your specific application.
- 3) By default, the system uses Auxiliary Input 1 as the interface. This setting can be modified in the controller's **Web Server** under **[Maintenance] > [Parameters] > [Interface Definition]**.

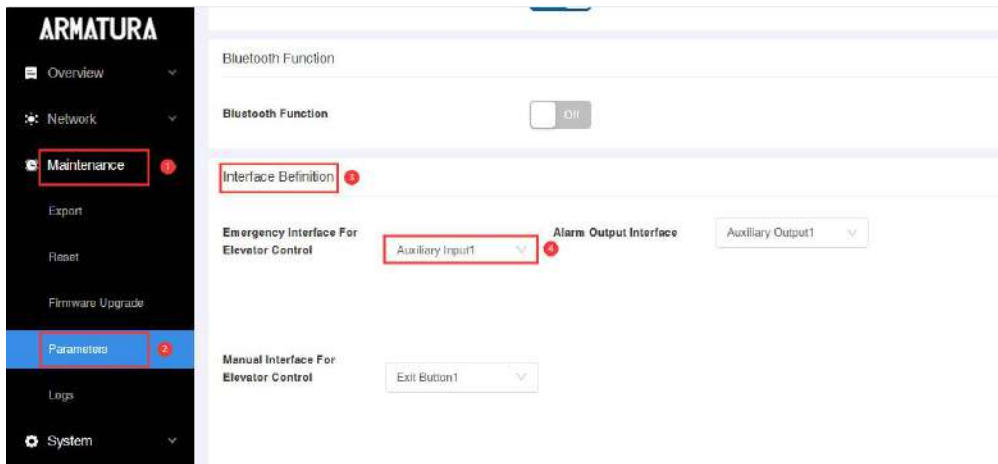

- 4) To activate this feature, the controller must be running MCU firmware **version 6.3.2.5** or higher.
- 5) In this elevator control system, the fire alarm interface has the highest priority, followed by the emergency interface, while the manual interface holds the lowest priority in the hierarchy.

1.7. REX Wiring

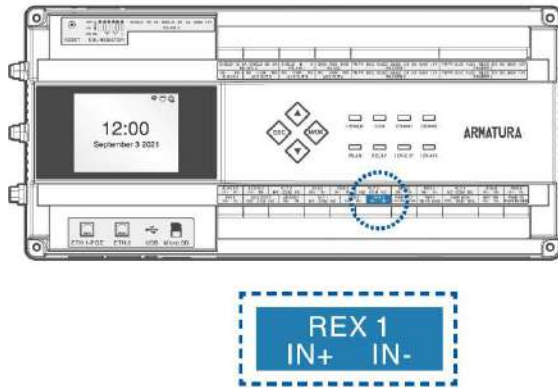

No Supervision

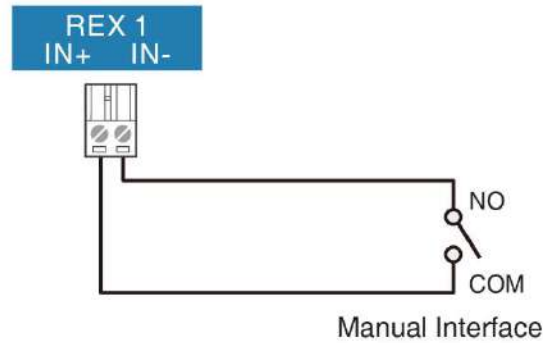

Default Supervision

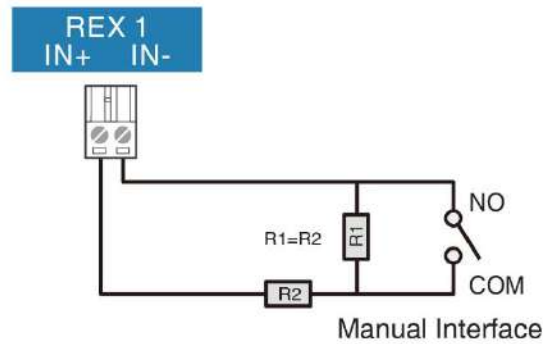

Note :

- 1) In the event of a short circuit at the manual interface, the elevator control system will release control of the elevator buttons, allowing unrestricted use of all floor button. Once the manual interface is restored, the system will automatically return to controlled operation.
- 2) The Manual Interface is an optional feature and does not need to be connected. Connect it only if required for your specific application.
- 3) The system defaults to REX 1 as the interface. This setting can be modified in the controller's **Web Server** under **[Maintenance] > [Parameters] > [Interface Definition]**.

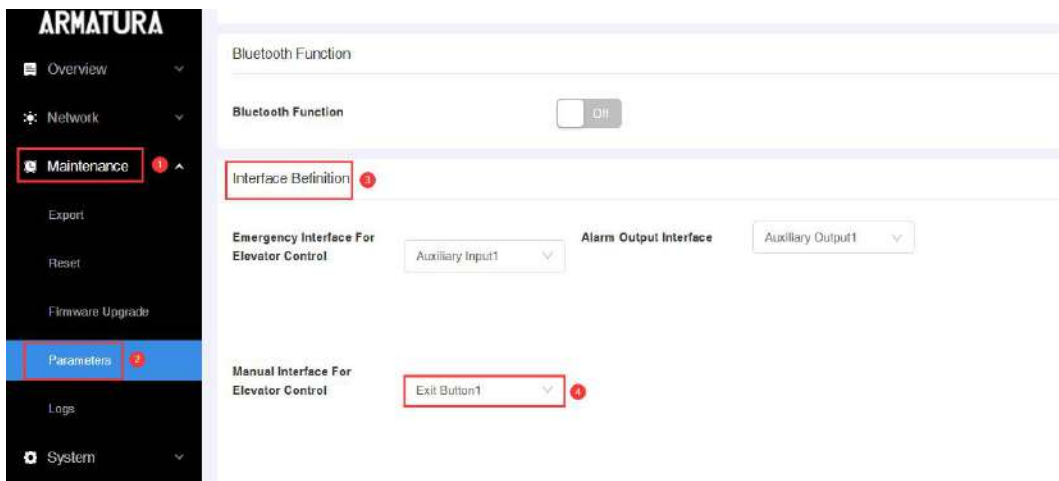

- 4) *To activate this feature, the controller must be running MCU firmware **version 6.3.2.5** or higher.*
- 5) *In this elevator control system, interface priority is as follow: Fire Alarm(highest), Emergency(medium), and Manual(lowest).*

1.8. Alarm Output Wiring

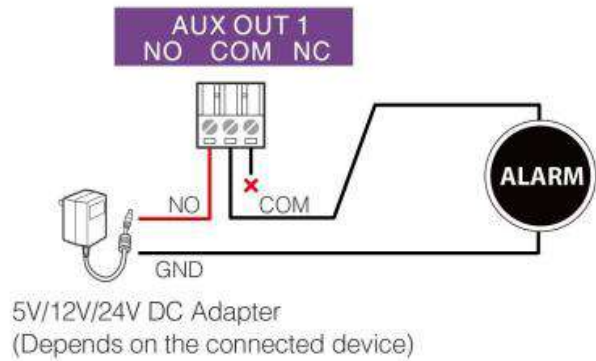

Note :

- 1) *The Alarm Output is an optional feature and does not need to be connected. Connect it only if required for your application.*
- 2) *Use the Alarm Output interface to connect an external alarm.*

2. Controller Configuration

1. Ensure that your controller is running firmware **version 10.0.15** or higher to enable the elevator control function.
2. If the firmware version is lower than the required version, contact technical support for assistance.

2.1. Configuring the Controller for Elevator Control

1. Open your web browser and enter the IP address of the controller to access its web server.
2. Log in to the controller's web server. Use the default username (armatura) and password (armatura) to log in to the controller's web server.



3. Navigate to **[System] > [Application Scenario]**.
4. Verify that the **[Scene]** setting is set to **[Elevator Control]**. If it is already selected, the system can be used directly. If not, change the setting to **[Elevator Control]**.
5. Click **[Save]** to apply the changes.

Note:

- 1) If the **[Application Scenario]** option does not appear under **[System]**, please contact technical support for assistance.

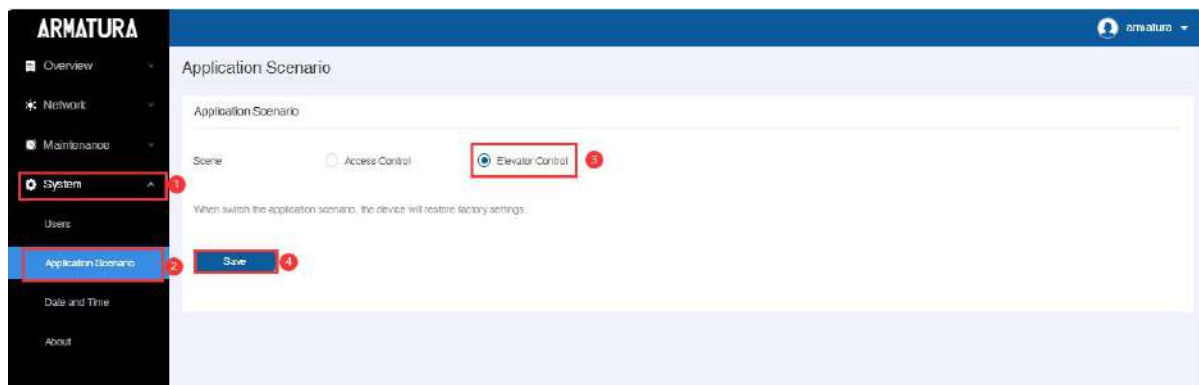

2.2. Configuring the Controller Network Parameters

1. After switching to Elevator Control mode, the controller will reset to factory settings and automatically restart.
2. The controller's IP address will be reset to its default value.
3. You can connect to the controller through Eth1 (default IP 192.168.1.201) or Eth2 (default IP 192.168.2.202).
4. The controller's web server password will also reset its default value.
5. Use the default username (armatura) and password (armatura) to log in to the controller's web server.



6. Modify the controller's network parameters under **[Network] > [Ethernet]**.
7. The settings shown in the image below are for reference only-adjust them according to your actual network configuration.

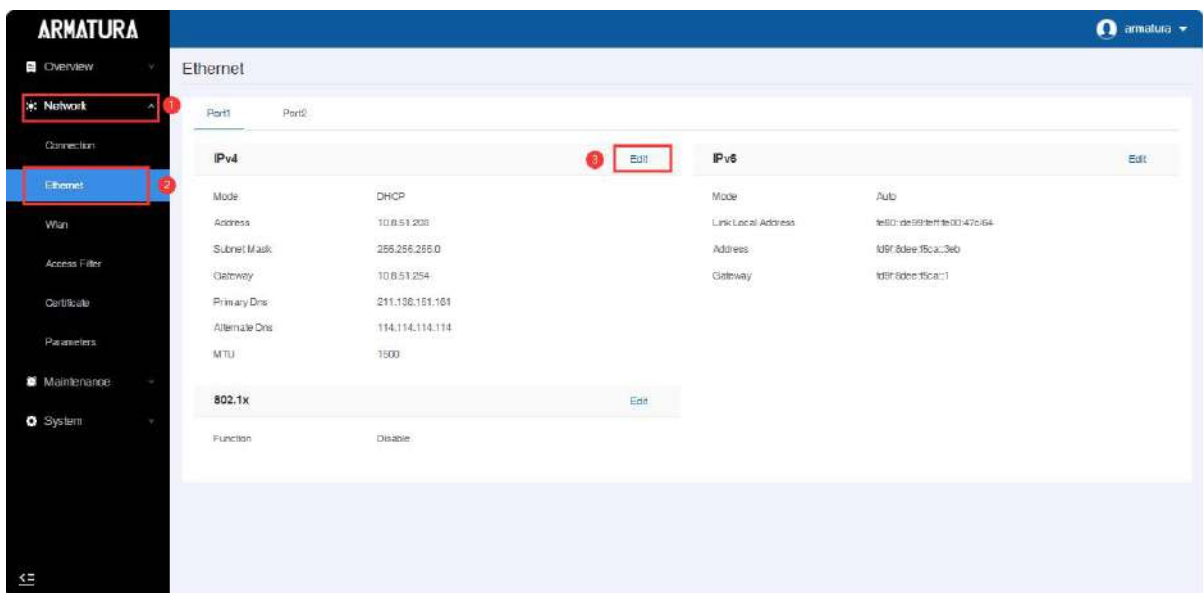

2.3. Configuring the Controller to Software Connection Parameters

1. The latest controller firmware supports both Easy Mode and Advanced Mode for adding the device to the software.
2. The following image is a reference for Easy Mode.
3. In the controller's web server, go to **[Network] > [Connect]**, then select **[Easy Mode]** under **[Deploy Mode]**.
4. Enter the IP address or domain name of the Armatura ONE software, with the default port set to 8088.
5. Enable both options in **[Software]**.
6. Finally, click **[Save]** to apply the settings.

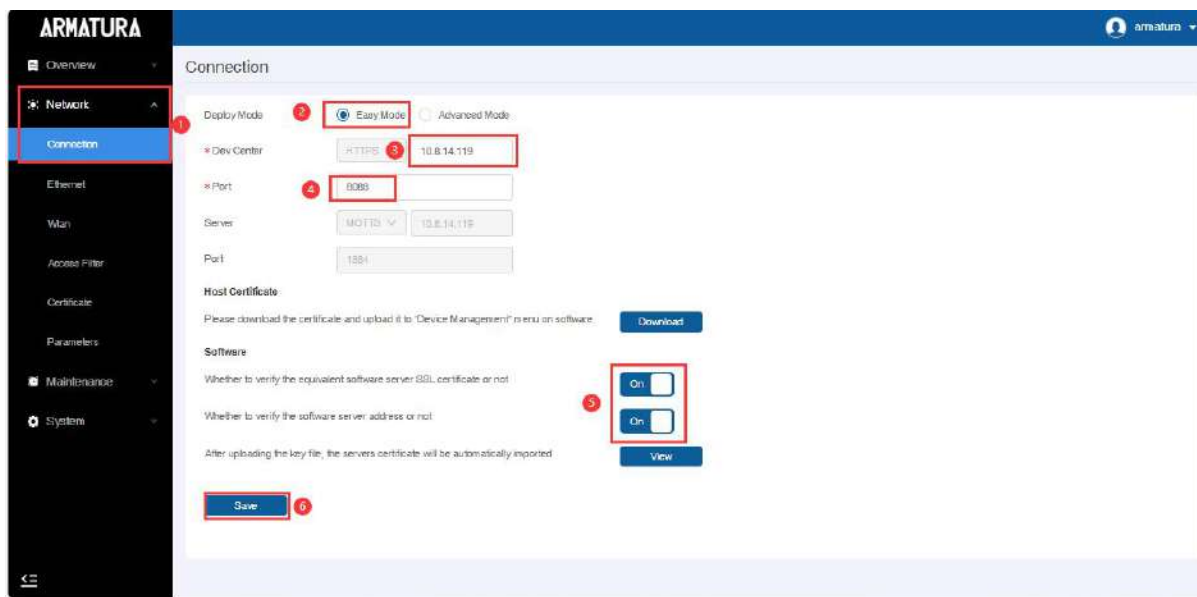

3. Armatura One Software Configuration

3.1. Adding a Device in Spada-MQTT Mode

1. Log in to the Armatura ONE software.
2. Navigate to **[System] > [Communication] > [Communication Services]**, then locate **[Spada-Mqtt Add Device Mode]**.
3. If the controller is operating in Standard Mode, select **[Standard Mode]**.
4. If the controller is operating in Advanced Mode, select **[Advanced Mode]**.
5. Click **[OK]** to save the setting and exit.

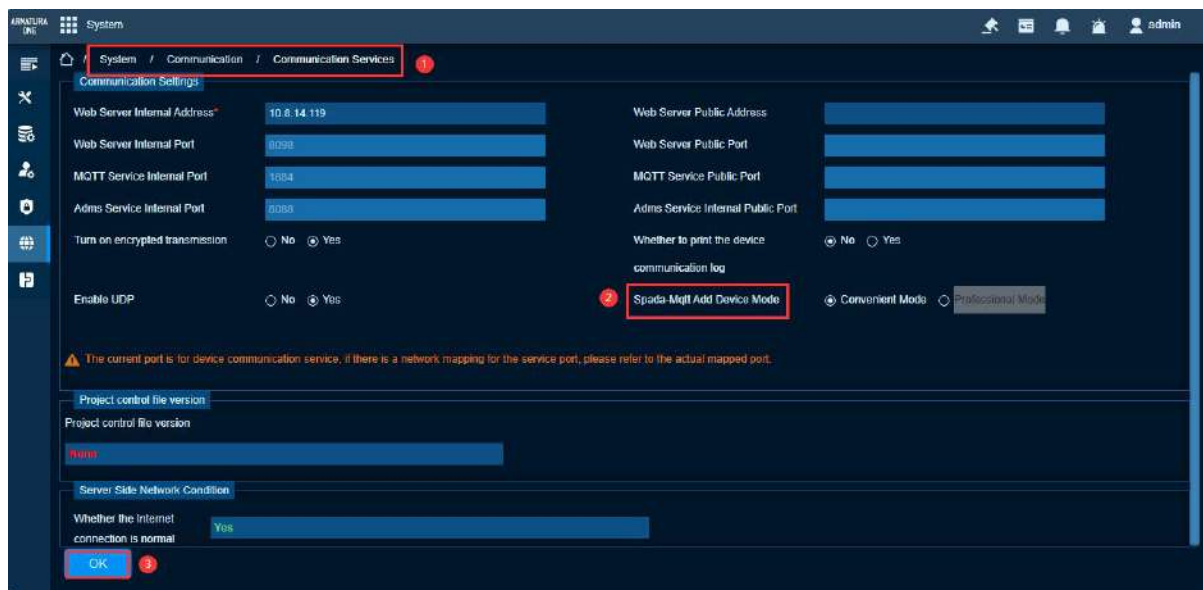

3.2. Verifying Controller Authorization

1. In **[System] > [Communication] > [Authorized Management]**, verify that the **[Module]** column for the controller's corresponding serial number displays **[ele]**.
2. If **[ele]** is displayed, the device is authorized.
3. If **[ele]** is not displayed, check the controller's connection settings.

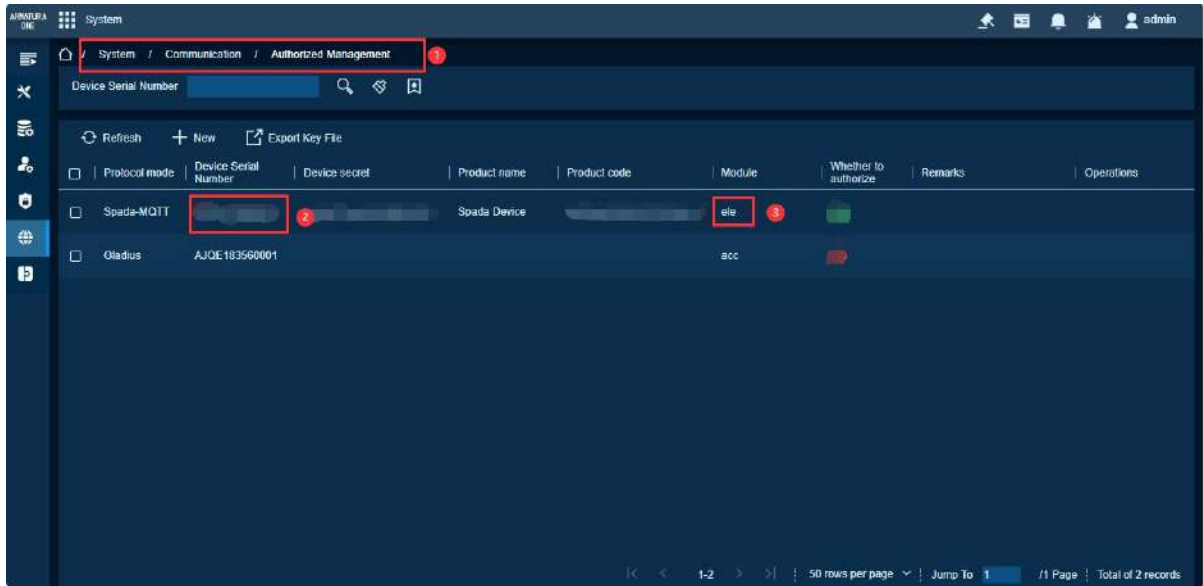

3.3. Adding Buildings, Floors, Elevator Groups, and Elevators

1. Go to **[Elevator] > [Elevator Settings] > [Building] > [New]** to add a building.

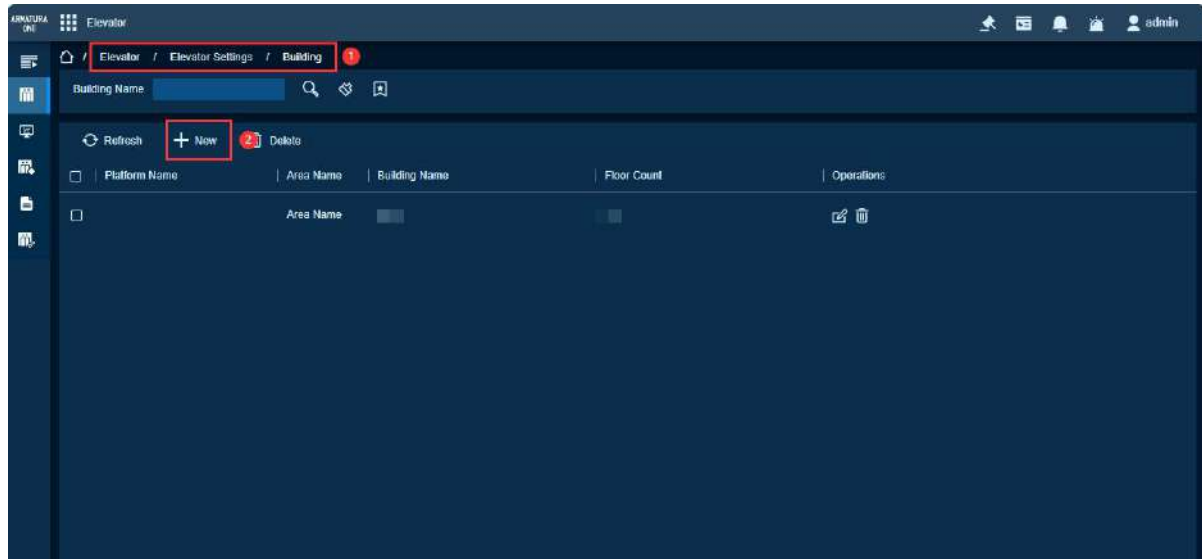

2. In the pop-up window, enter the building information according to the actual requirements.
3. For example, in the test building show below, there are 13 floors above ground and 1 floor below ground, for a total of 14 floors.
4. Set **[Floor Count]** to 14 and **[Floor name starts at]** to B1.

[Floor name starts at] field description :

- 1) **[B] or [-]:** Indicates basement floors. For example, the second basement level is denoted as **[B2]** or **[-2]**.
- 2) **[1] and [L]:** Indicated the first floor or lobby, typically denoted as **[1]** or **[L]**.

5. Finally, click **[OK]** to save and exit.

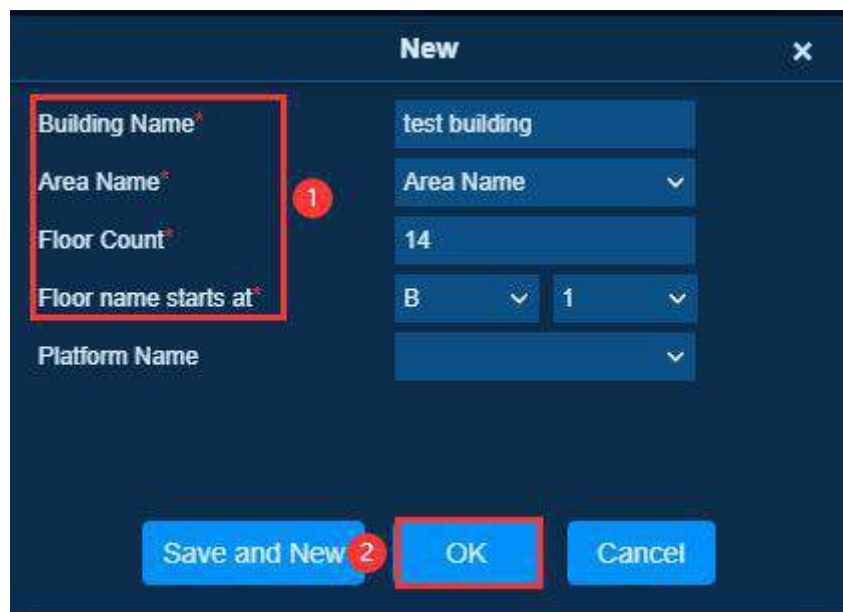

6. After adding the building, the generated floors will be displayed on the **[Floor]** page.

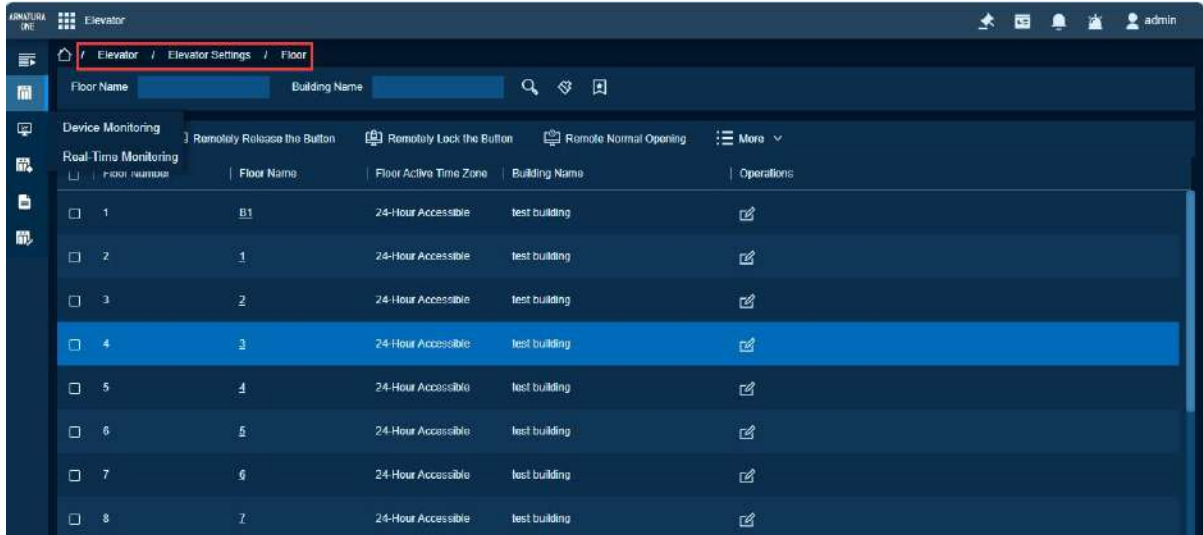

7. Navigate to **[Elevator] > [Elevator Settings] > [Elevator Group]**, then click **[New]** to add a new elevator group.
8. In the pop-up window, select the building and enter the elevator group number(NO) and name.
9. Click **[OK]** to save and exit.

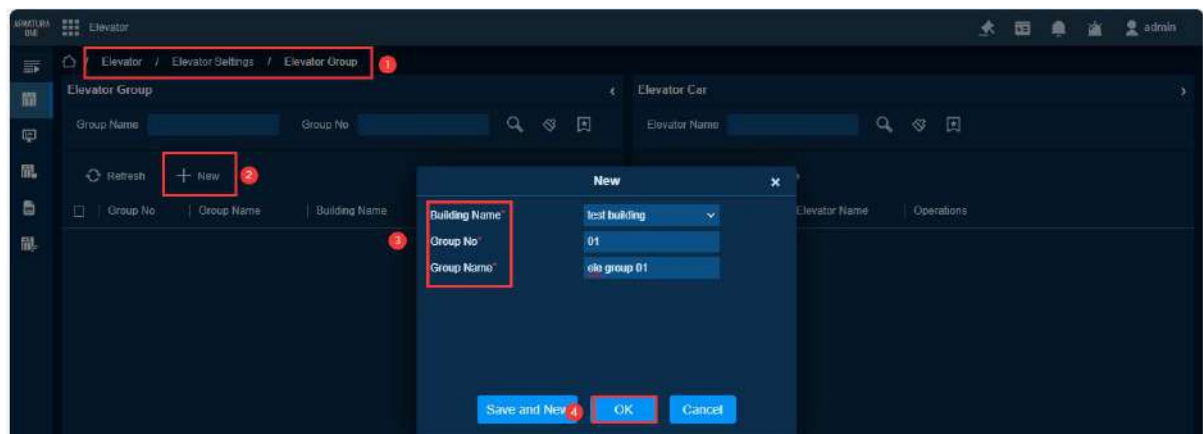

10. Click the **[Add]** button to add elevators to the selected elevator group.
11. Add the elevators and assign names based on the actual number of elevators in the group.

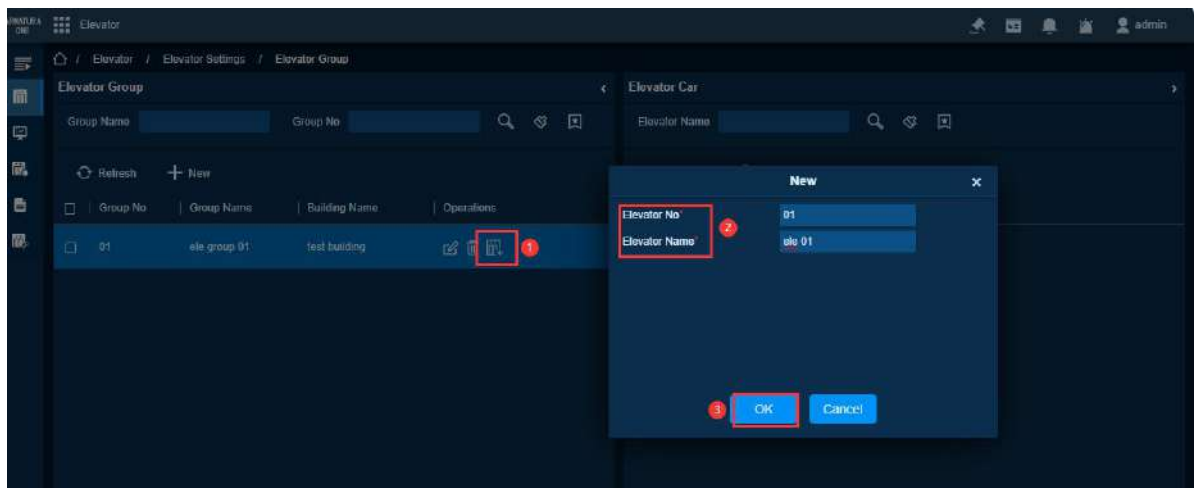

12. After adding, the generated elevator cars will be displayed on the **[Elevator Car]** page.
13. As this stage, the auxiliary outputs have not yet been assigned to the **[Elevator Car]**, so it is not yet operational.

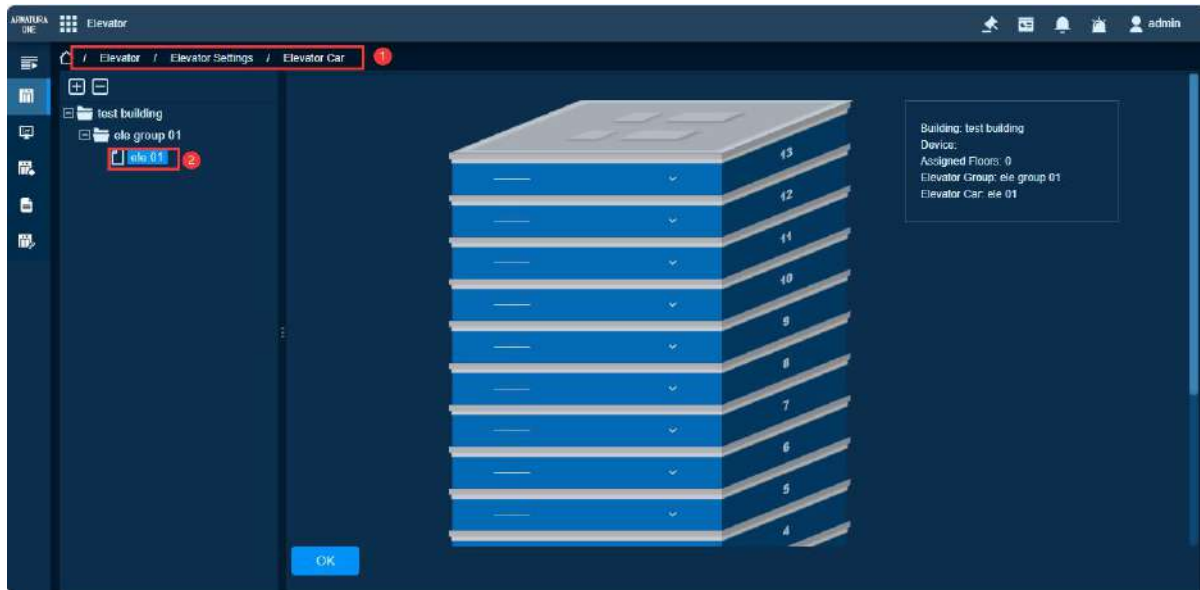

3.4. Adding an Elevator Controller

1. The following example demonstrates adding a device in Standard Mode.
2. Navigate to **[Elevator] > [Elevator Settings] > [Device]**, then click **[Search]** to begin searching for devices.

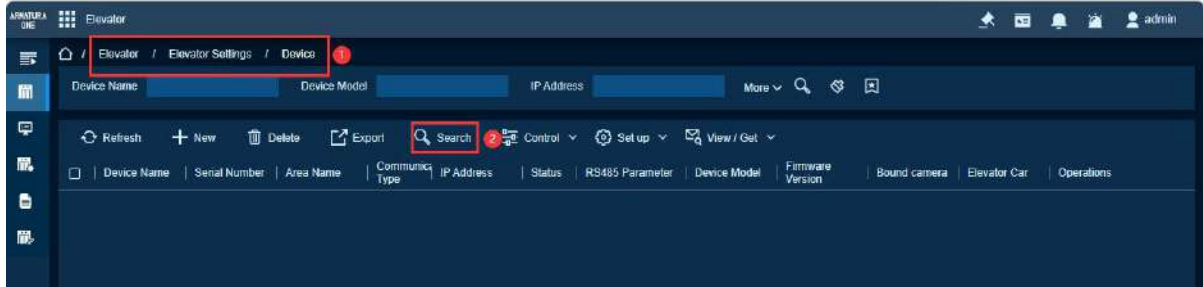

3. Click **[Search]**, and once the search is complete, click the **[+]** icon next to the target device to add it.



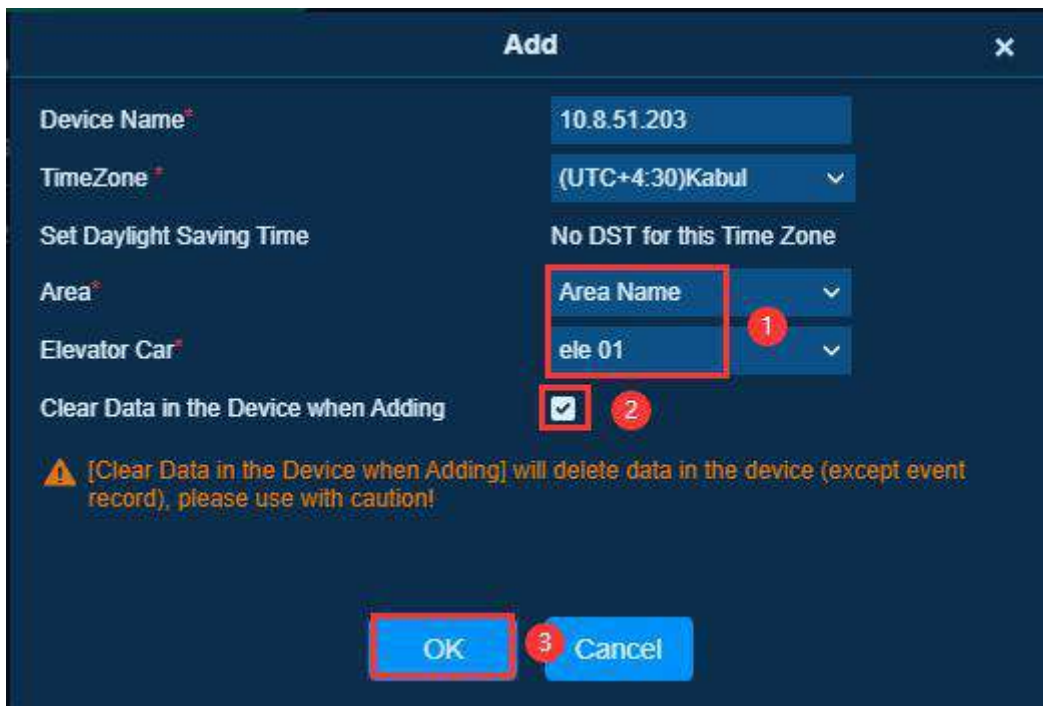

4. In the pop-up window, assign the device to an area and an elevator car, then select **[Clear Data in the Device when Adding]**.
5. Click **[OK]** to save and exit.

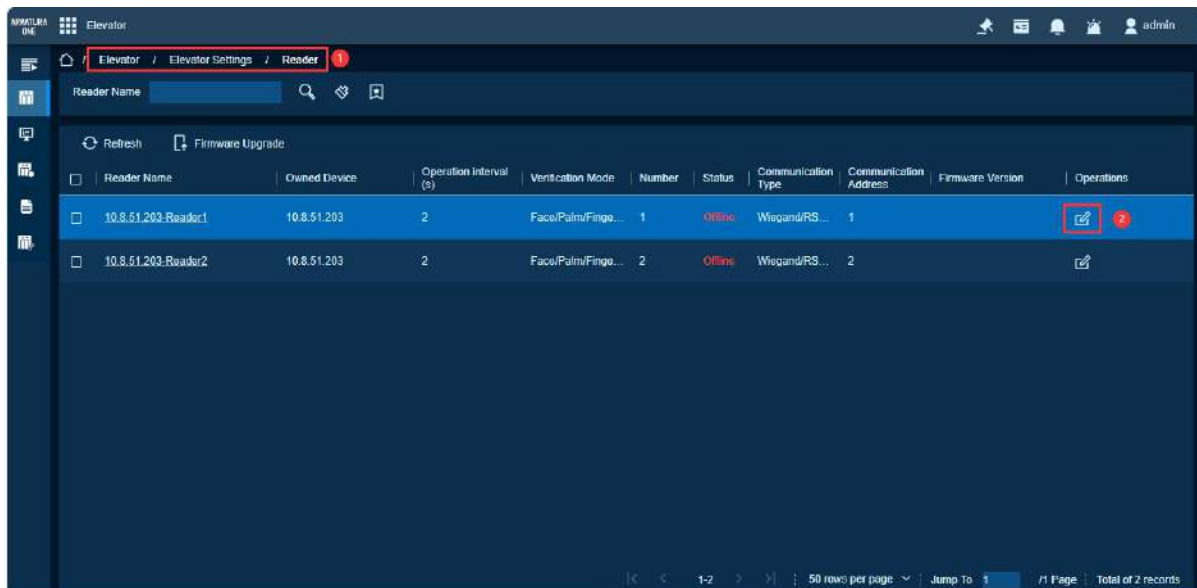

3.5. Configuring Reader Parameters

1. After adding the device, the system will automatically generate the corresponding number of readers on the controller type—for example, 4 readers for an AHDU-1260 controller.



2. Click the  icon on the right side of the target reader to modify its configuration settings.
3. The images below are for reference only. Adjust the configuration according to the actual wiring and reader settings.

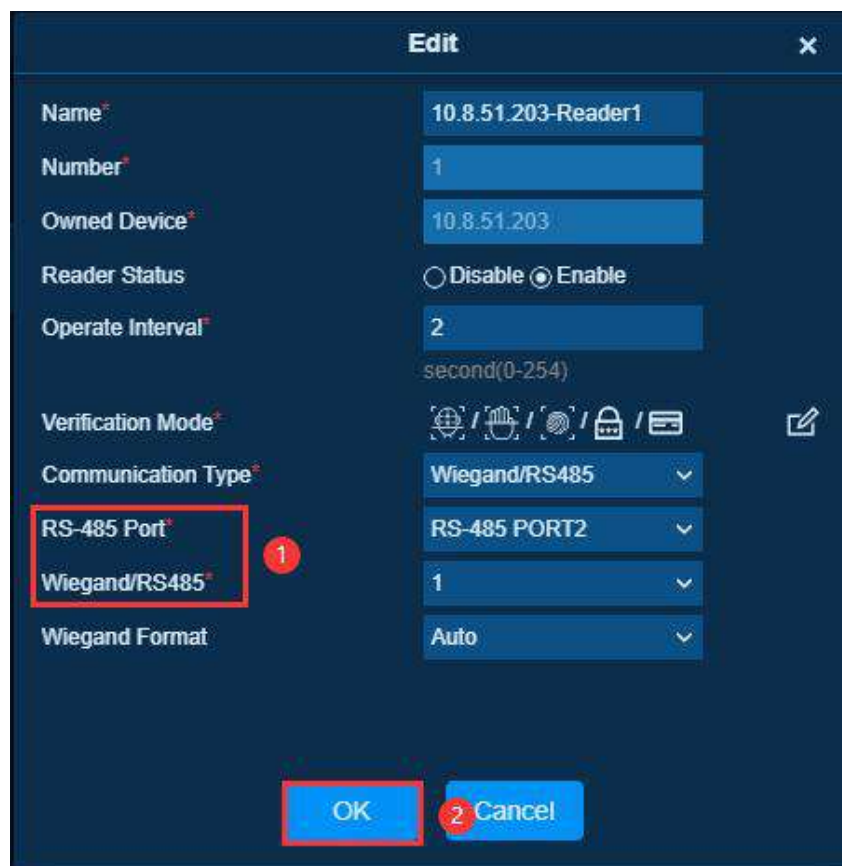

4. After the modifications are saved, the reader’s status will update to Online.

The screenshot shows the ARMATURA ONE Elevator control interface. At the top, there is a navigation bar with the breadcrumb path: Elevator / Elevator Settings / Reader. Below this is a search bar for 'Reader Name' and a 'Firmware Upgrade' button. The main content area contains a table with the following columns: Reader Name, Owned Device, Operation interval (s), Verification Mode, Number, Status, Communication Type, Communication Address, Firmware Version, and Operations. Two rows of data are visible, both with 'Online' status highlighted in green. The footer of the table shows pagination controls: '< > 1-2 >>' and '50 rows per page'. The status bar at the bottom indicates '1 Page' and 'Total of 2 records'.

Reader Name	Owned Device	Operation interval (s)	Verification Mode	Number	Status	Communication Type	Communication Address	Firmware Version	Operations
10.8.51.203-Reader1	10.8.51.203	2	Face/Palm/Finge...	1	Online	Wiegand/RS...	1	RD Ver_14_180.15	
10.8.51.203-Reader2	10.8.51.203	2	Face/Palm/Finge...	2	Online	Wiegand/RS...	2		

3.6. Adding I/O Boards

1. Navigate to **[Elevator] > [Elevator Settings] > [I/O Board]**, then click **[New]** to add a new I/O Board.

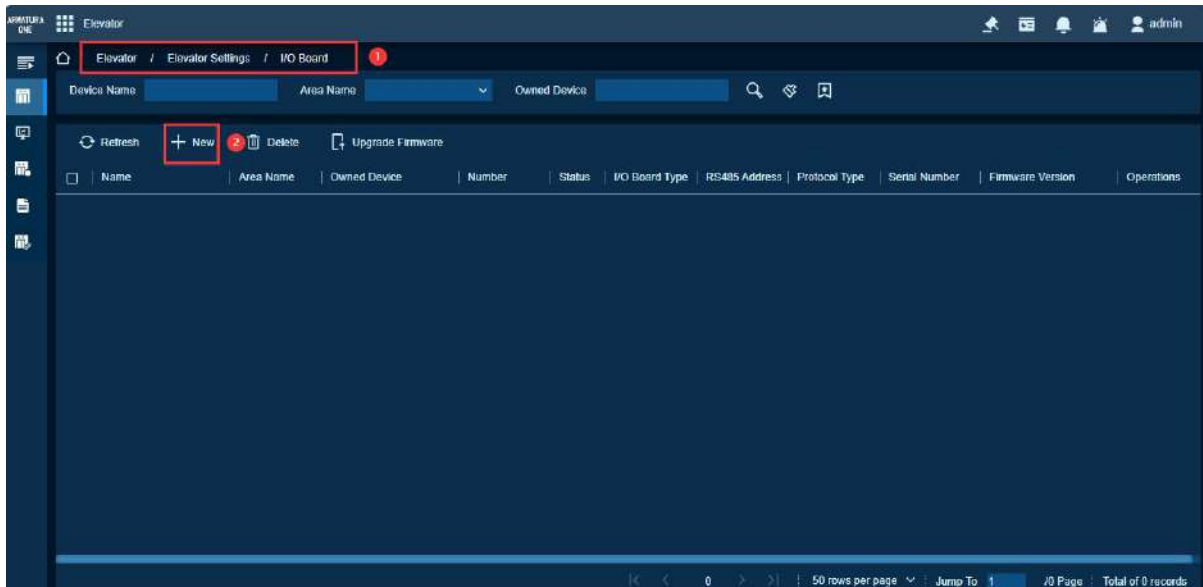

2. In the pop-up window, enter a name for the I/O board and select the target controller.
3. Configure the necessary parameters, then click **[OK]** to save and exit.

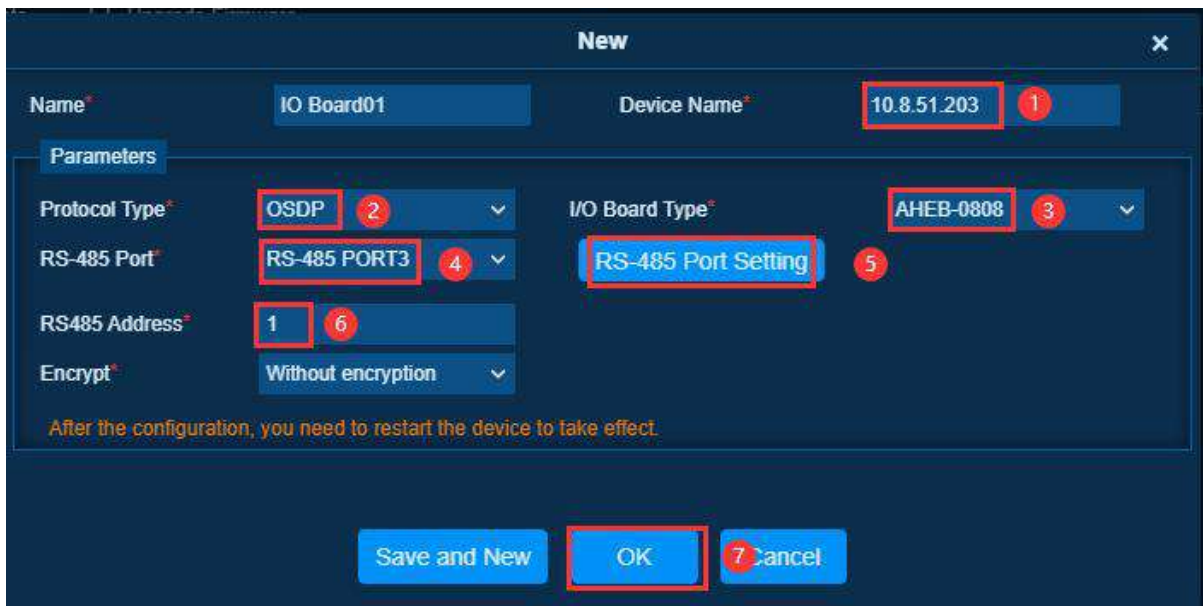

The key field description is as follows :

- 1) **[Protocol Type]:** Select **[OSDP]**.
- 2) **[I/O Board Type]:** Select the option that matches the actual I/O board model.
- 3) **[RS-485 Port]:** Select the port according to the actual wiring of the I/O board.
- 4) **[RS-485 Port Setting]:** Set the baud rate of the port connected to the I/O board to 9600.



- 5) **[RS-485 Address]:** Enter the address based on the DIP switch settings of the I/O Board. The DIP switches use a binary format and should be read from left to right.

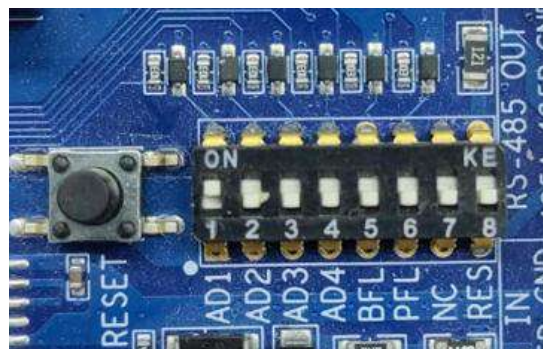

- 6) **[Firmware Version]:** Ensure the I/O Board firmware is version 1.0.18 or higher to support the elevator control function. If the firmware version is below this requirement, contact your local branch or headquarters technical support for assistance.

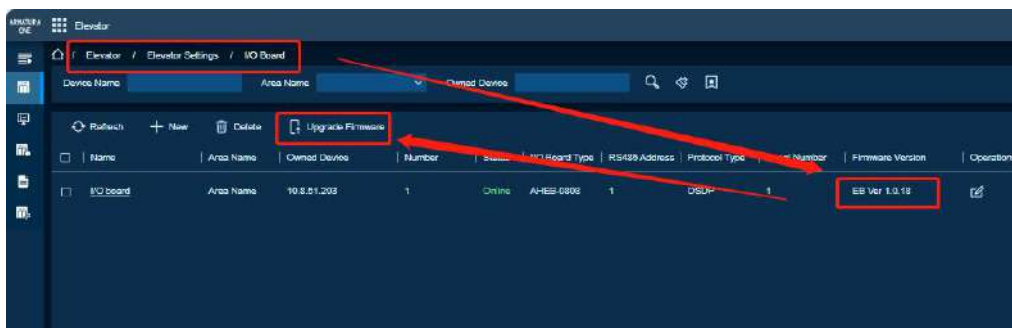

3.7. Modifying Auxiliary Output Points for Floor Assignment

1. After successfully adding the elevator controller and I/O Boards and bringing them online, the system will automatically assign all auxiliary output points to the corresponding floors.
2. Navigate to **[Elevator] > [Elevator Settings] > [Elevator Car]**. Based on the actual wiring, click the  icon on the right side of each floor to modify it to the correct auxiliary output point.

Note :

- 1) The I/O Board uses auxiliary output ports to connect to the elevator's button signal lines.
- 2) The controller connects to the elevator's button signal lines using relay ports instead of auxiliary outputs. To use the onboard relay for floor control, the controller must be running MCU firmware **version 6.3.2.5** or higher. If the controller is not updated to this version, floor control must instead be achieved through the I/O Board's auxiliary outputs. For assistance, please contact technical support.

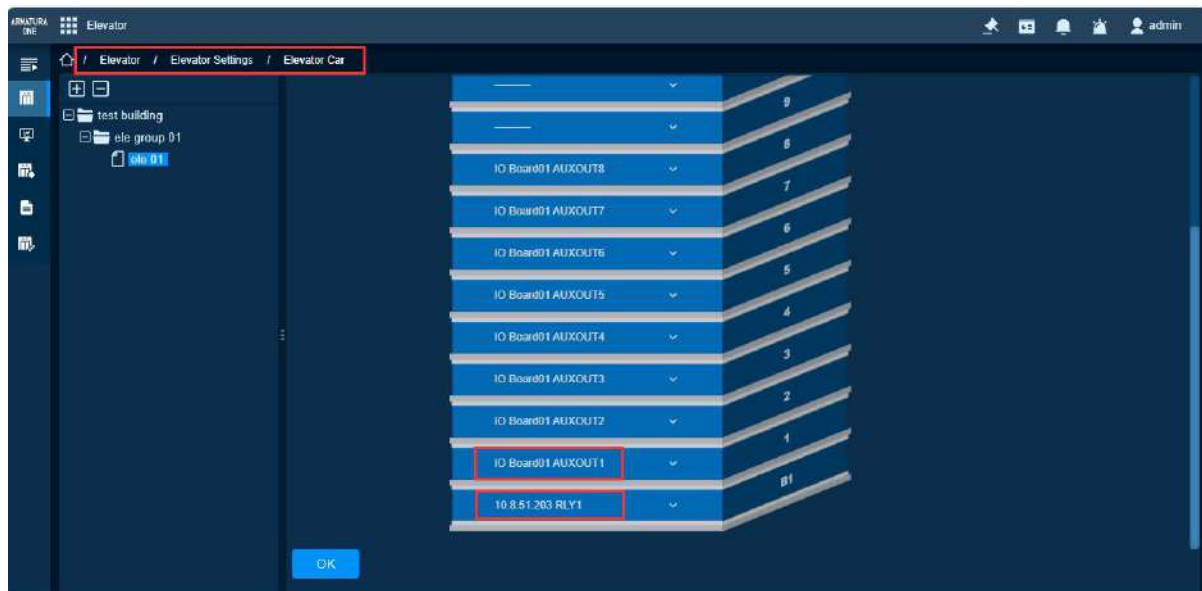

3.8. Adding Time Zones and Elevator Levels

1. The system includes a default time zone named **[24-hour Accessible]**, which can be used automatically.
2. Additional time zones can be created as needed.

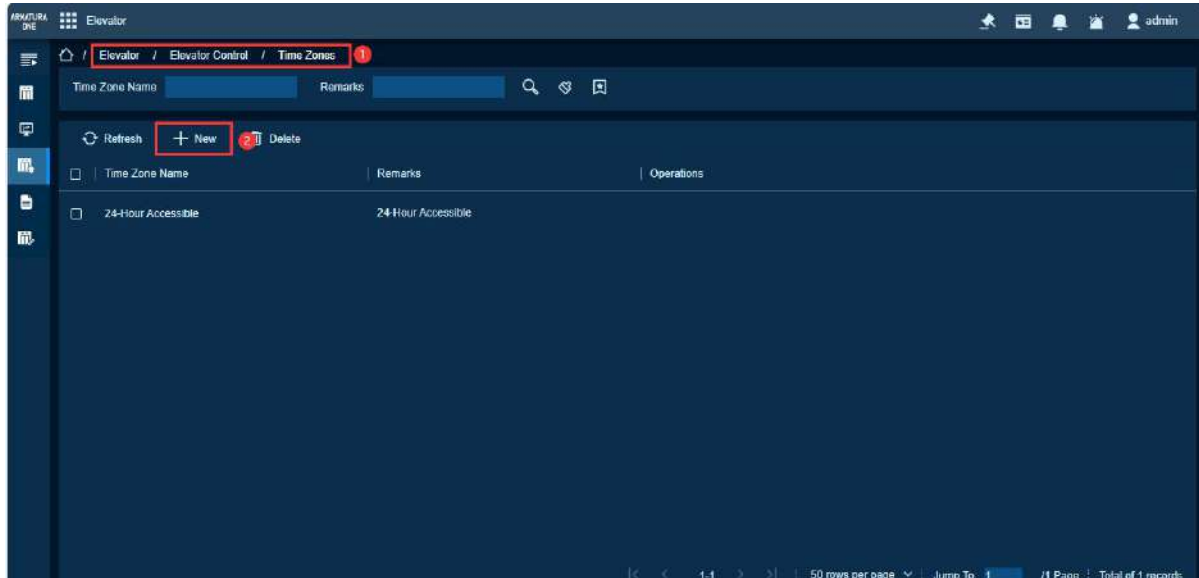

3. Navigate to **[Elevator] > [Elevator Control] > [Elevator Levels]** > the click **[New]** to add a new elevator level.
4. In the pop-up window, enter a name for the elevator level, select the area, and configure the required settings.
5. Click **[OK]** to save and exit.

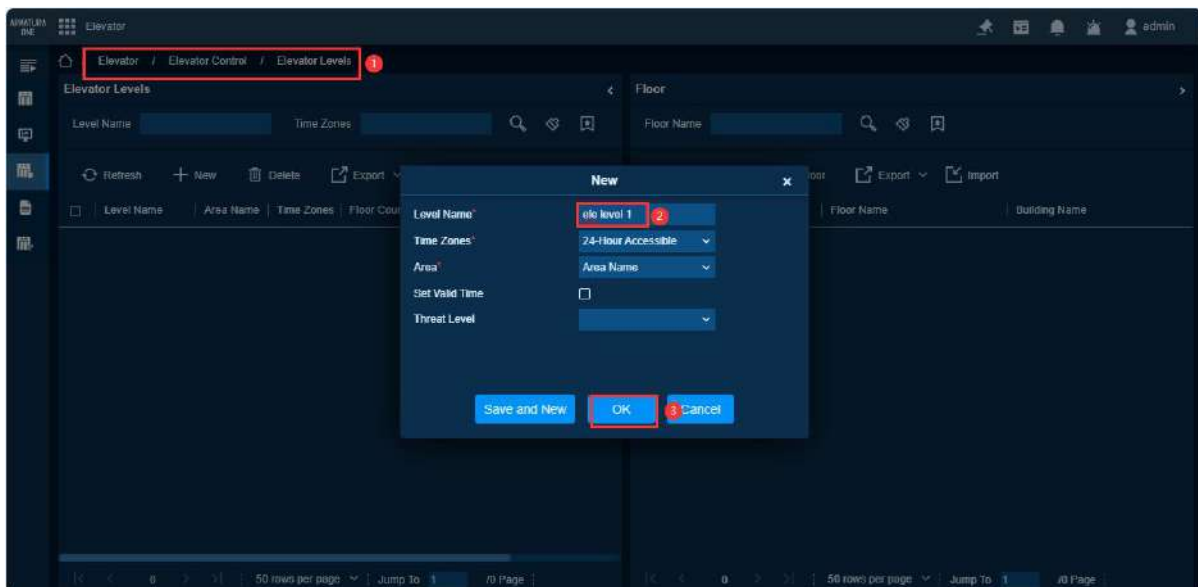

6. After adding the elevator level, the system will display a configuration prompt.
7. Click **[OK]** to continue.

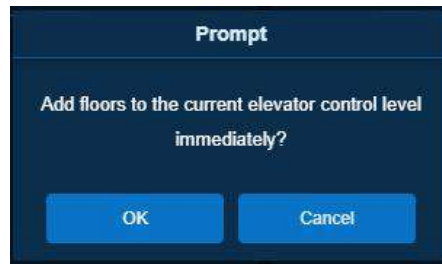

8. Select the floors to include in this level by checking the appropriate boxes, then click the  **[Add]** button.
9. Click **[OK]** to save and exit.

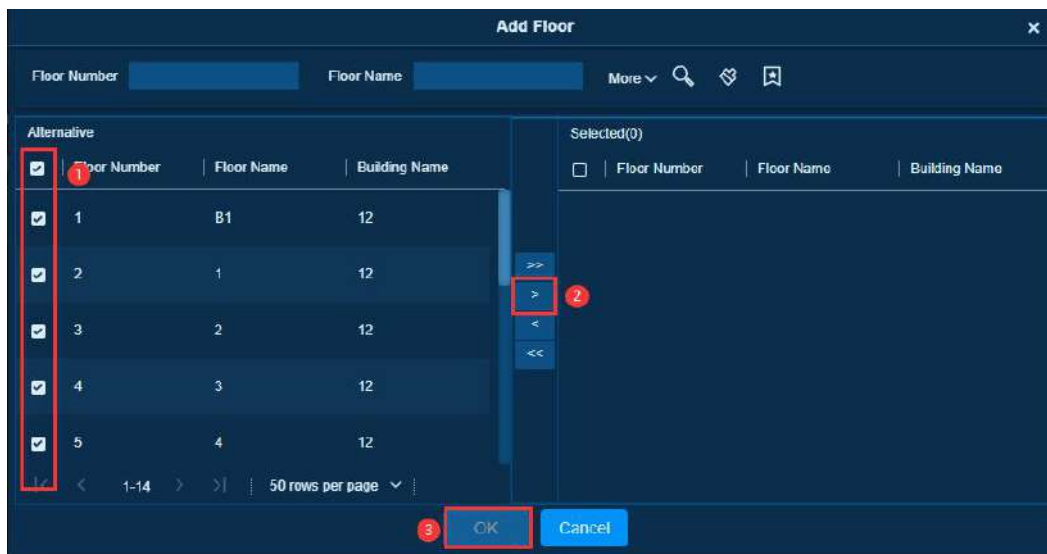

10. If you missed this prompt, go to the **[Elevator Levels]** page, drag the scrollbar to the far right, and click the  button to re-enter the page.

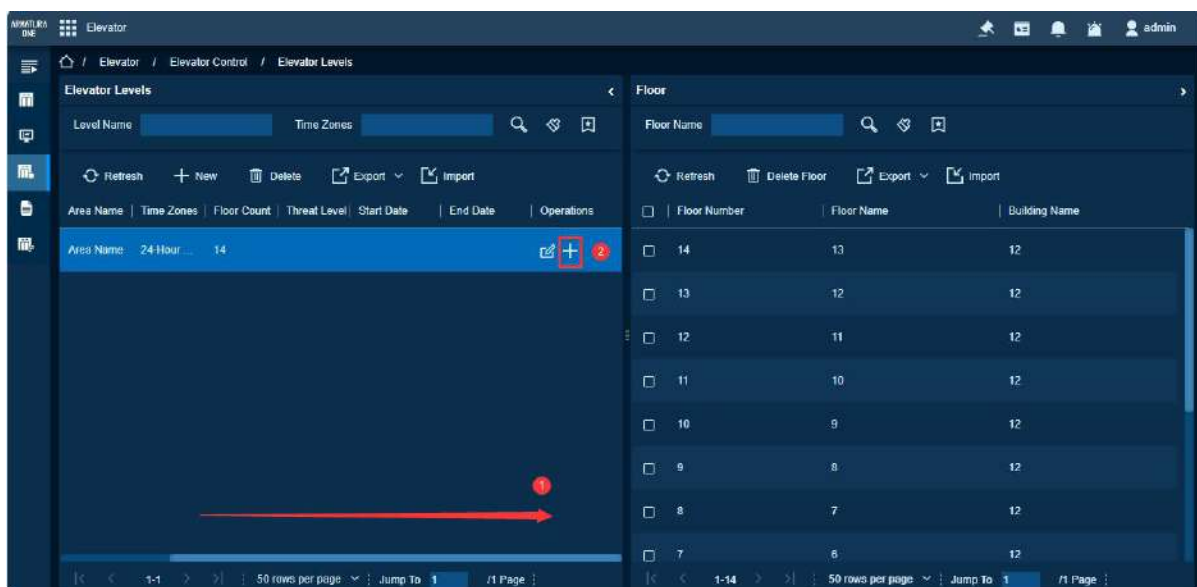

3.9. Adding Personnel and Configuring Elevator Controls

1. Navigate to [**Personnel**] > [**Personnel Management**] > [**Personnel**], then click [**New**] to add new personnel.

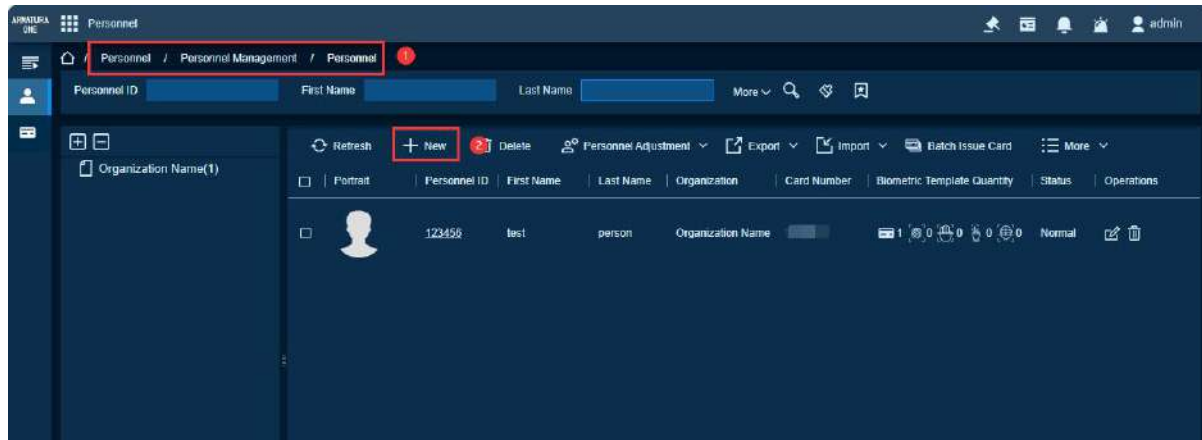

2. In the pop-up window, enter the person’s basic information.
3. Scroll down to the [**Elevator Control**] section and click [**Add**] to assign the appropriate permissions.
4. When finished, click [**OK**] to save the settings and exit.

Note :

- 1) [**Superuser**]: Grants access to all floors.
- 2) [**Default Floor**]: Only one default floor can be set per building. Supported only on AHEB-1616 or DCS elevators. Not supported on AHEB-0808 or AHEB-1602.
- 3) [**Open Side**]: Do not configure. Support only on DCS elevator.
- 4) [**Call Type**]: Do not configure, Supported only on DCS elevators.
- 5) [**Allow Lifts**]: Do not configure, Supported only on DCS elevators.

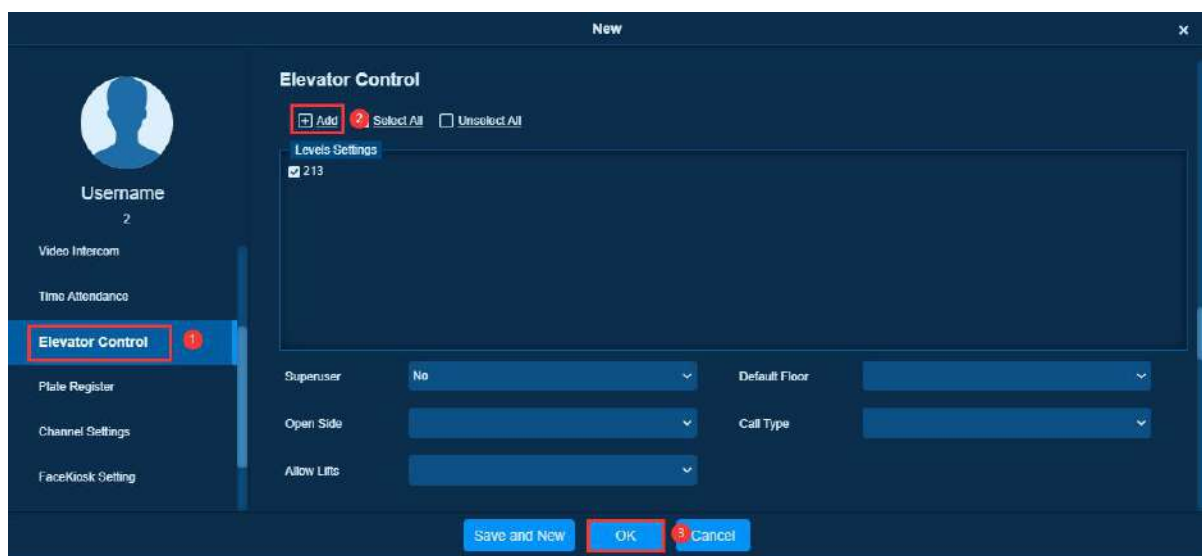

4. Verifying Elevator Control Function

1. After completing the step, present a card to the reader connected to the elevator controller for verification.
2. Once verified, the elevator system will illuminate the floor button corresponding to the user's access permissions.
3. The software will generate an **[Access Granted]** event record under **[Elevator] > [Monitoring] > [Real-Time Monitoring]**.
4. When the user presses the button for an authorized floor, the software will generate another event record: **[Button Pressed by Granted]**.

Note:

- 1) The **[Button Pressed by Granted]** record can only be accurately captured when using the AHEB-1616 I/O Board.

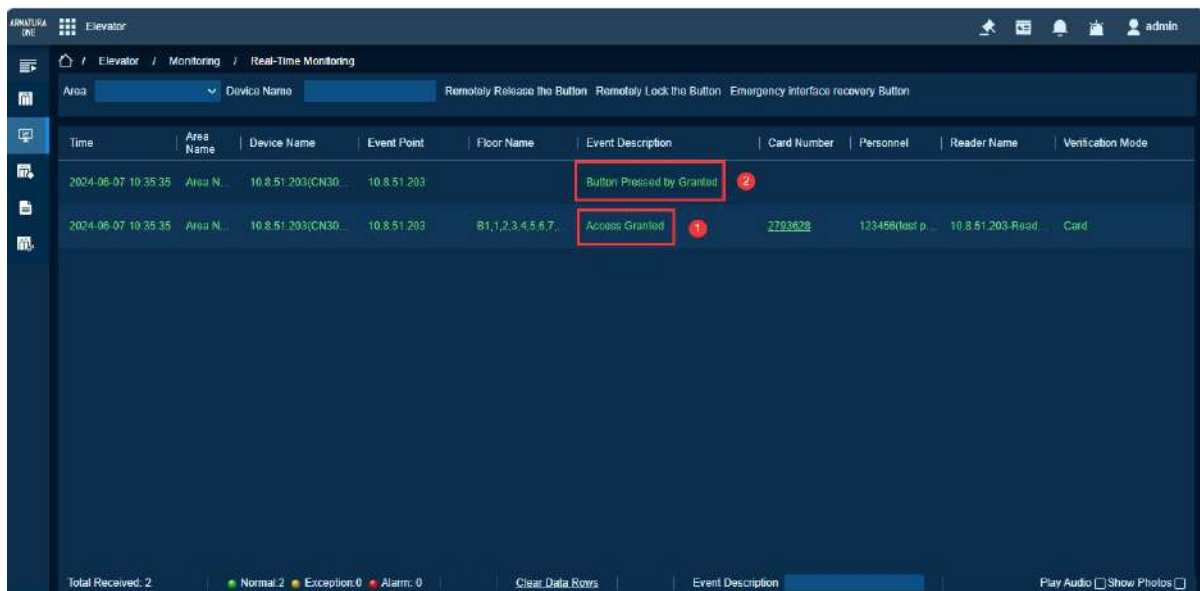

5. Appendix 1 - Elevator Control and Button Wiring

5.1. Method 1- Common Anode Button Connection

1. Supports floor selection and direct floor selection.

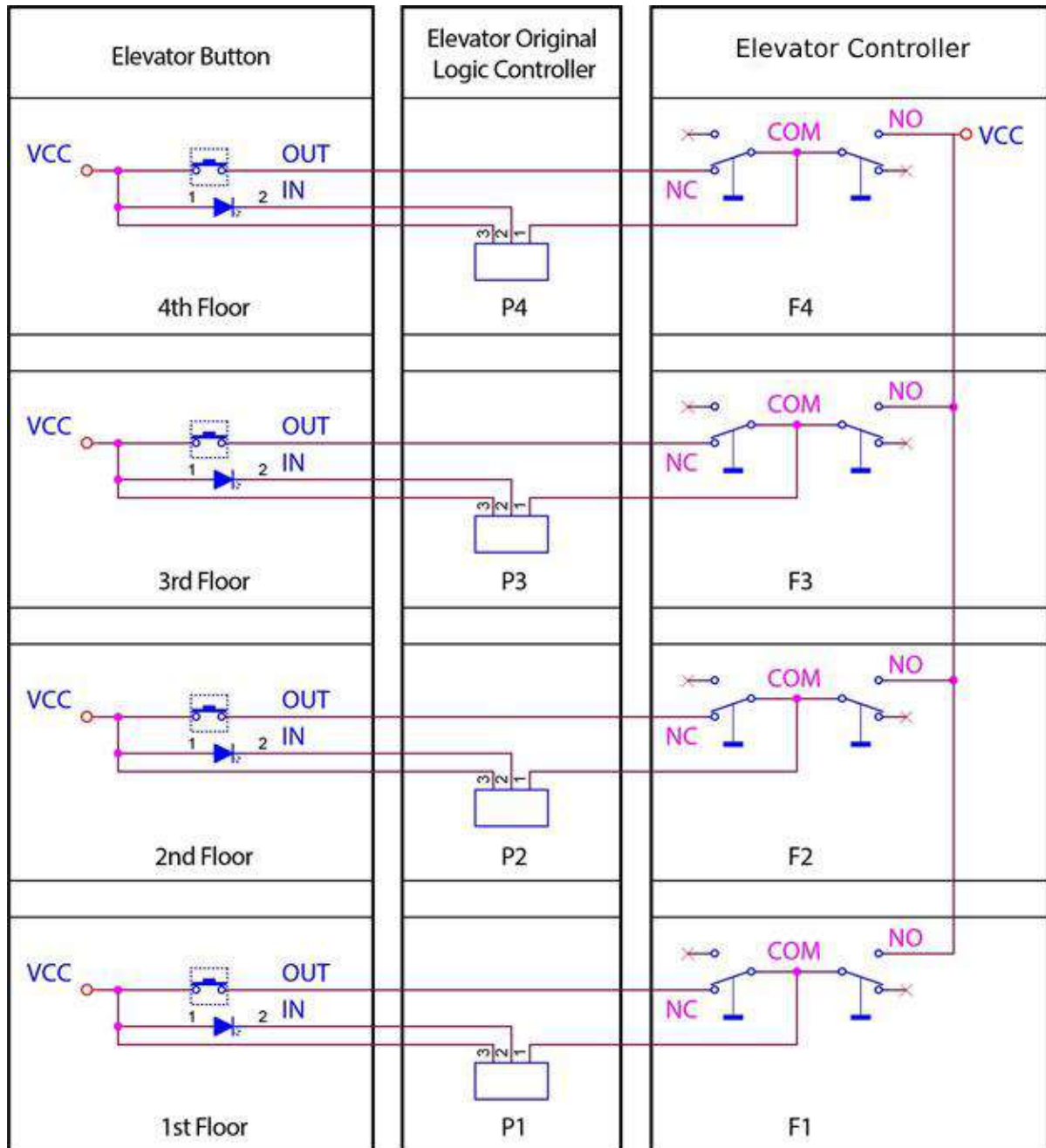

2. Supports floor selection only.

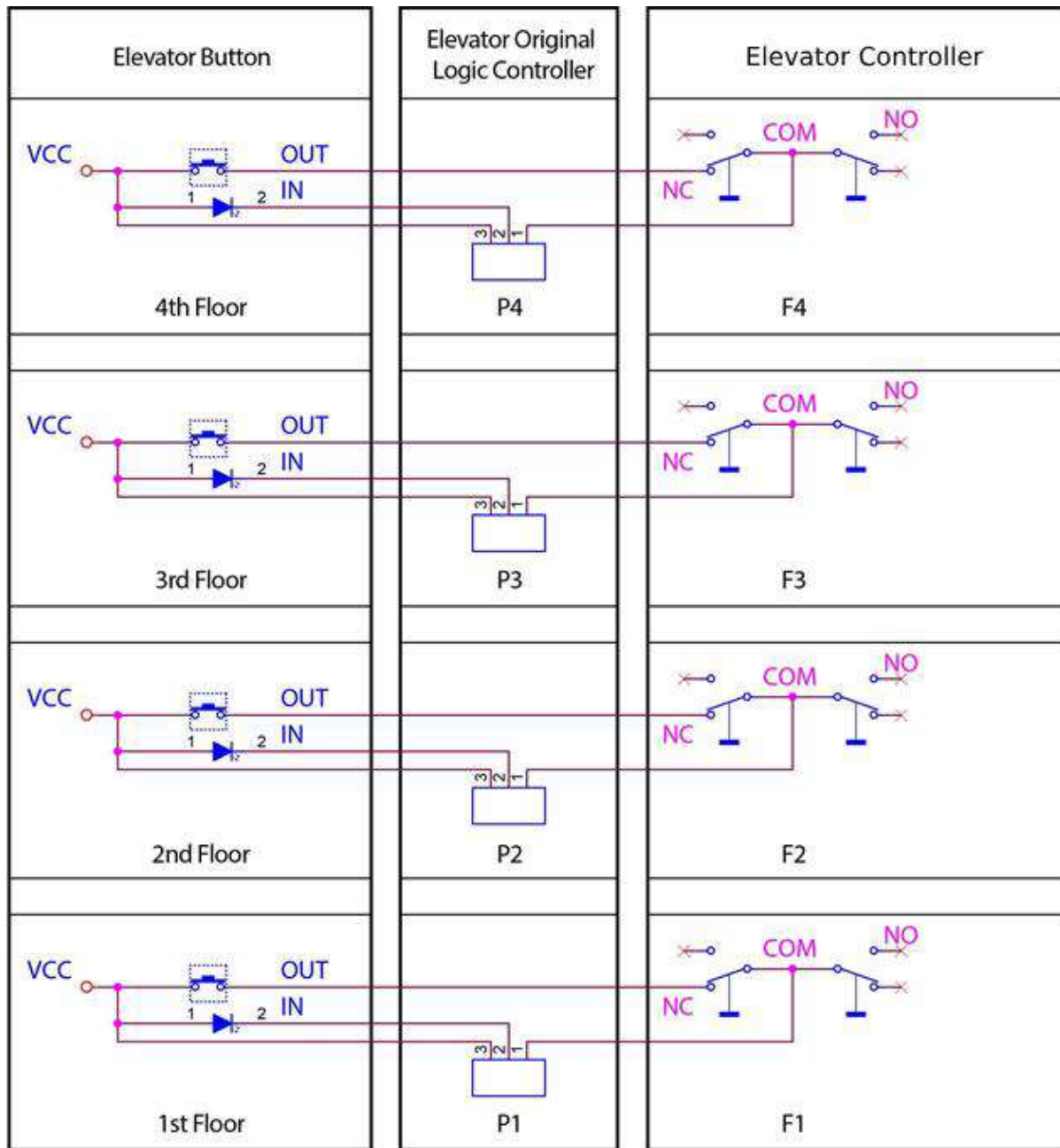

3. Wiring method when multiple identical buttons exist on the same floor.

Note:

- 1)The figure below illustrates the wiring method for an elevator with three button boards.
- 2)This wiring method prevents button cancellation exceptions.

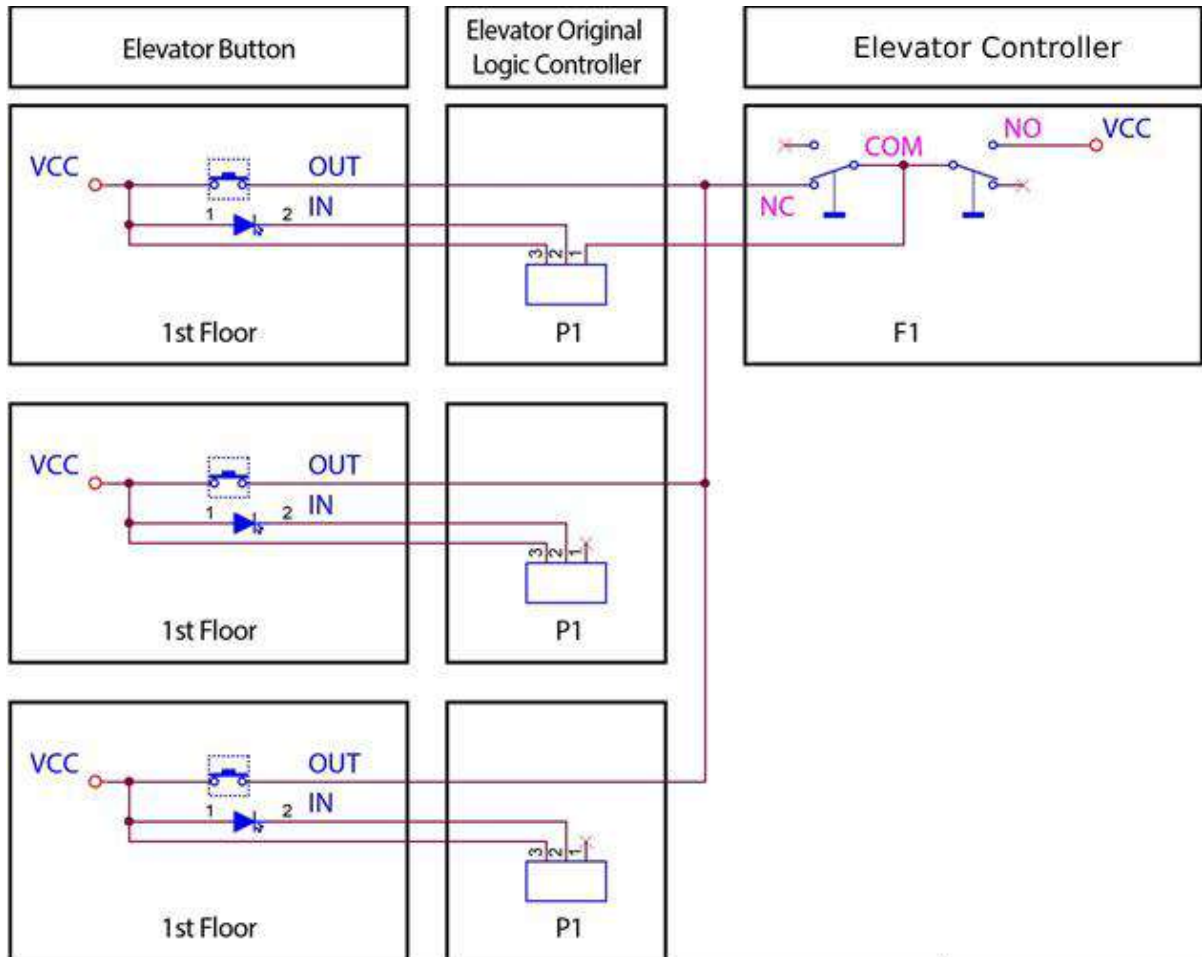

5.2. Method 2 - Common Cathode Button Connection

1. Supports floor selection and direct floor selection.

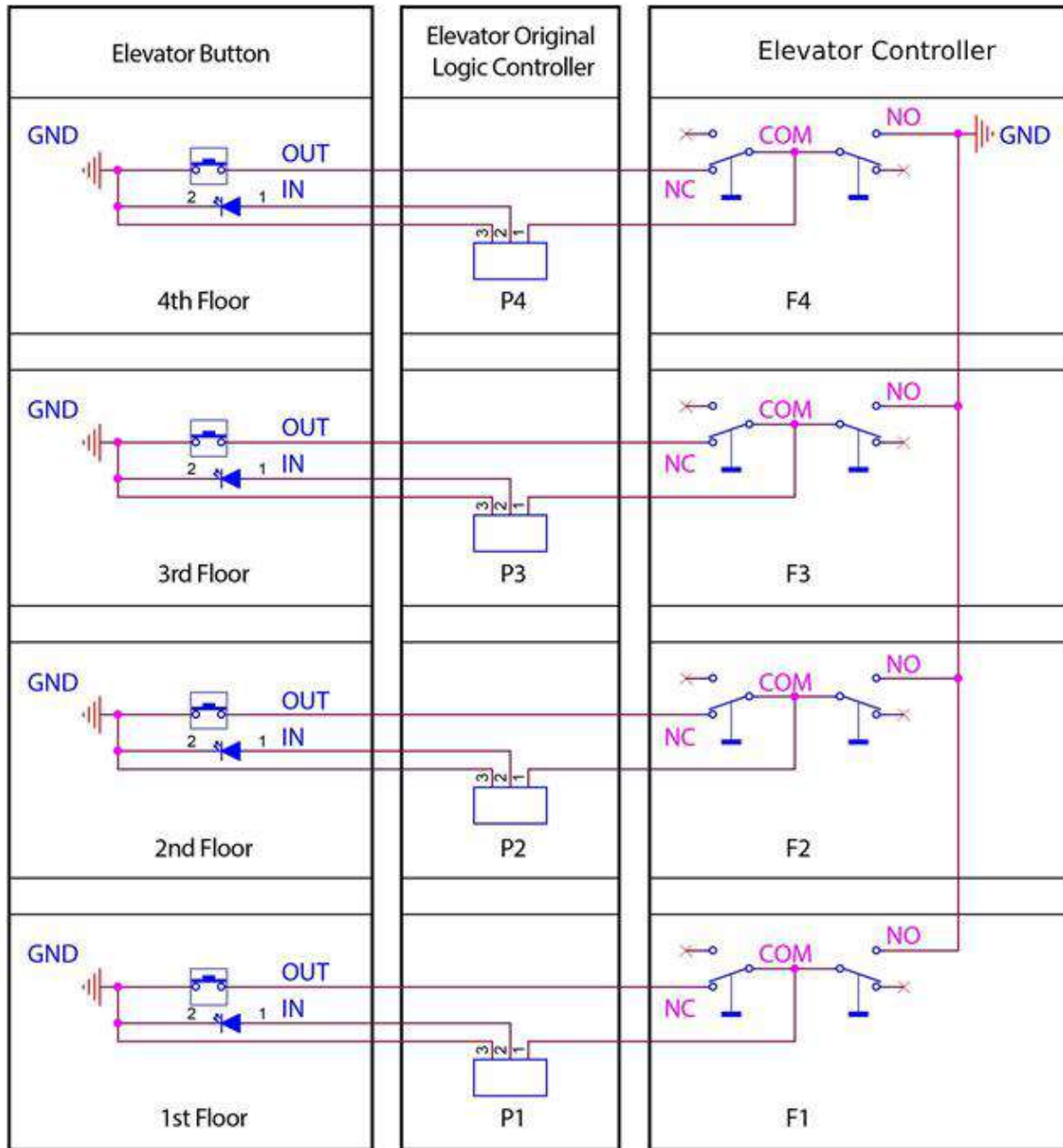

2. Supports floor selection and direct floor selection.

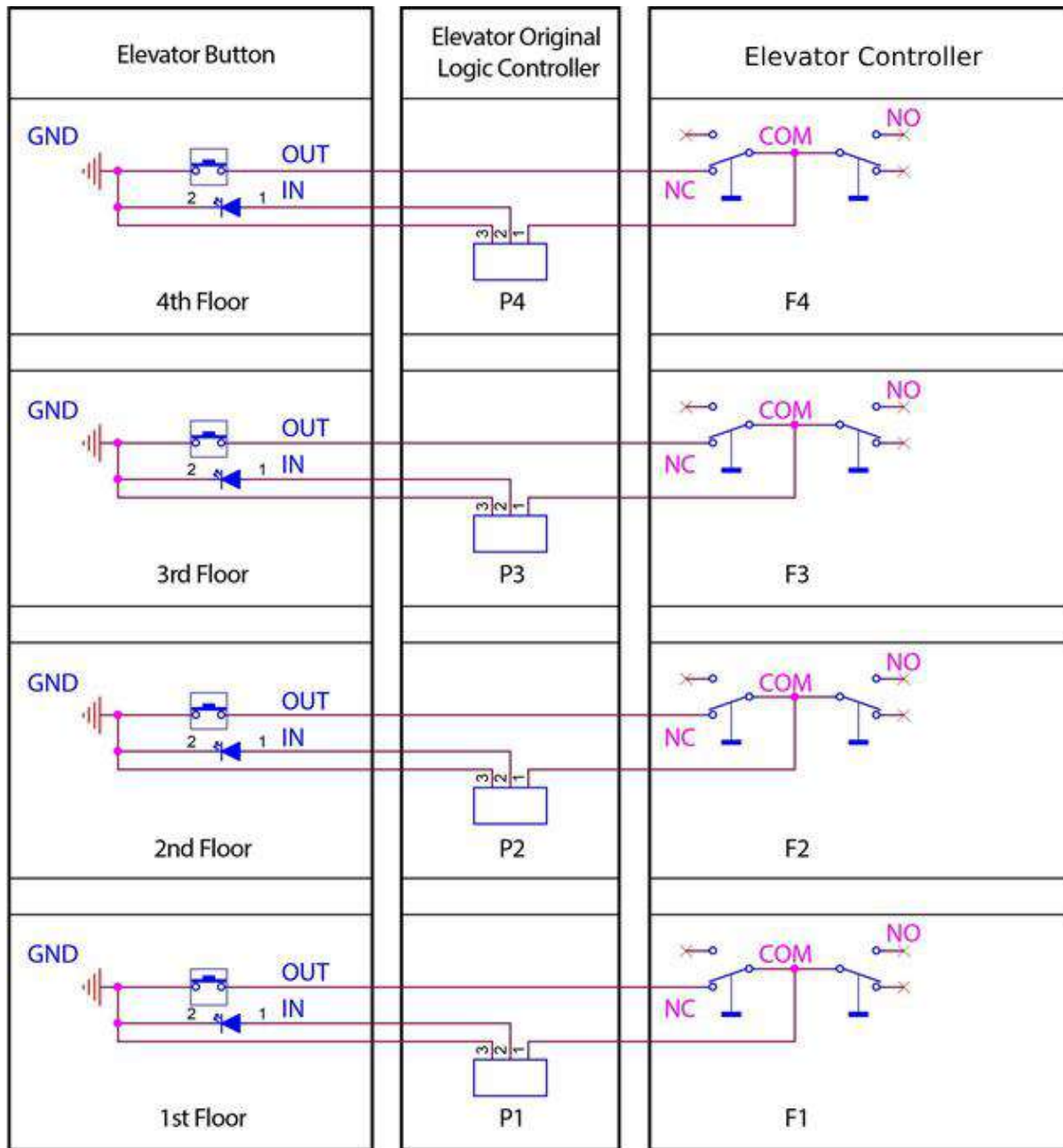

3. Wiring method for cases where multiple identical buttons exist on the same floor.

Note:

1) The following figure shows the wiring method for an elevator with three button boards, and this connection method avoids button cancellation exceptions.

2) This connection method prevents button cancellation exceptions.

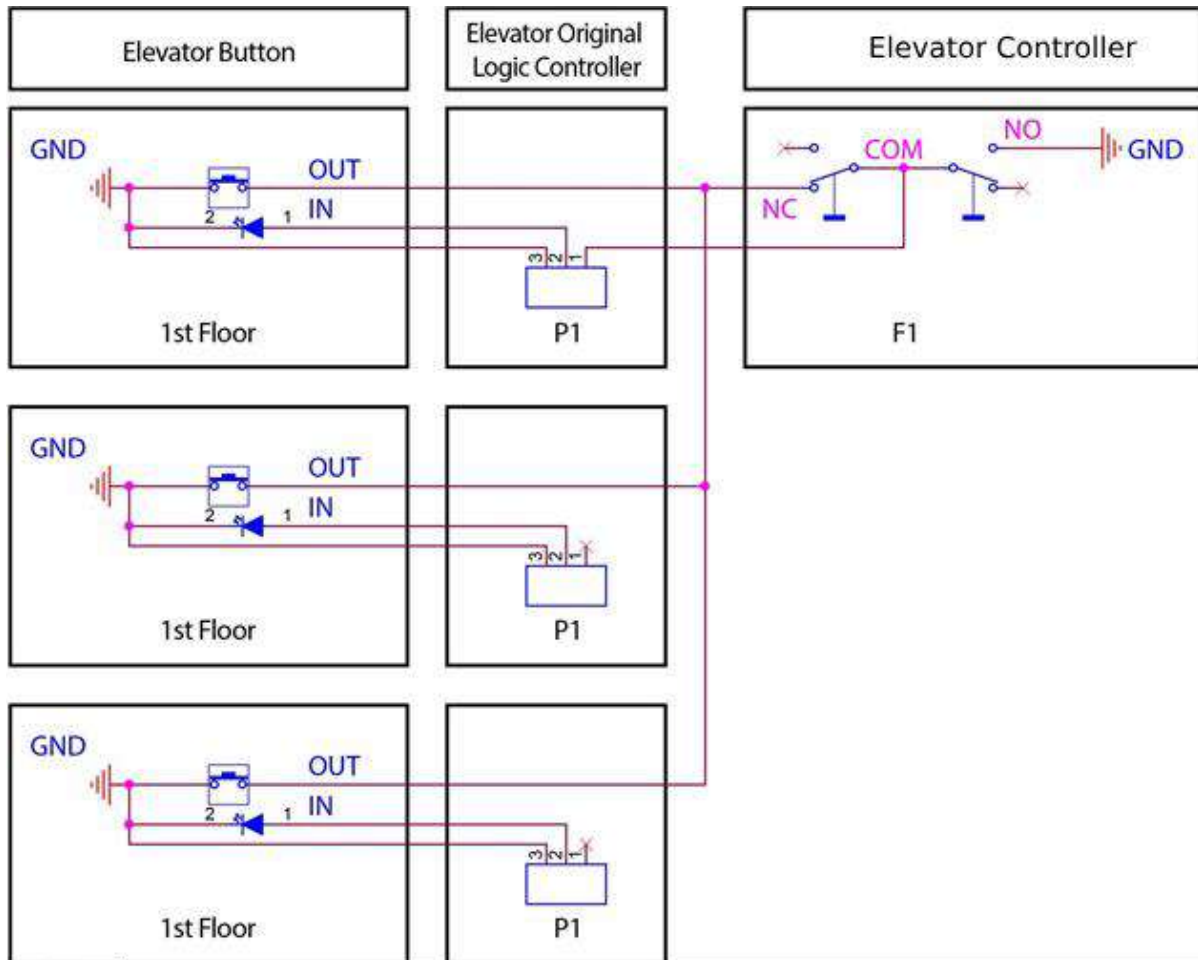

ARMATURA

ARMATURA LLC www.armatura.us E-mail: sales@armatura.us
Copyright © 2025 ARMATURA LLC. All rights reserved.